

GPSCOM 190

OWNER'S
MANUAL &
REFERENCE

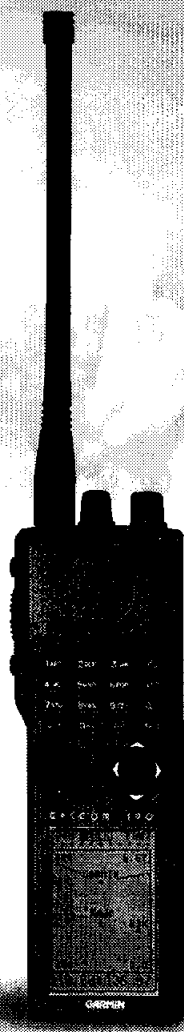

 **GARMIN.**

Software Version 2.03 or above

© 1996 GARMIN Corporation
1200 E. 151st Street, Olathe, KS USA 66062

GARMIN (Europe) LTD
Unit 5, The Quadrangle, Abbey Park Industrial Estate, Romsey, U.K. SO51 9AQ

All rights reserved. No part of this manual may be reproduced or transmitted in any form or by any means, electronic or manual, including photocopying and recording, for any purpose without the expressed written permission of GARMIN.

Information in this document is subject to change without notice. GARMIN reserves the right to change or improve its products and to make changes in the content without obligation to notify any person or organization of such changes or improvements.

GARMIN, AutoLocate, AutoStore, AutoZoom, GPSCOM, PhaseTrac12, and TracBack are all trademarks of GARMIN Corporation and may not be used without its expressed permission.

November 1996 Part #190-00110-00 Rev. B Printed in USA.



IMPORTANT!

The Telecommunications Act of 1996, effective February 8, 1996, provides the FCC discretion to eliminate radio station license requirements for aircraft and ships. At the present time, you do not need an individual license to operate the GPSCOM 190 aboard your private aircraft in many circumstances. To find out the specific details on whether you are exempt from licensing, please see FCC Fact Sheet PR 5000 or contact the FCC at 1-800-322-1117.

Note that no license is required for a portable radio used only as a backup on an aircraft which already has a station license per FCC 404 Instructions dated 1994.

If an aircraft license is required or desired, contact the FCC at 1-800-322-1117 to request FORM 404, Application for Aircraft Radio Station License.

If the GPSCOM 190 transmitter will be used as a ground station (from the ground outside of an aircraft), contact the FCC at 1-800-322-1117 to request FCC Form 406, Application for Ground Radio Station Authorization in the Aviation Services.

The FCC also has a fax-on-demand service to provide forms by fax at 1-202-418-0177.

The GPSCOM 190 owner accepts all responsibility for obtaining the proper licensing before using the transmitter.



GPSCOM 190 OWNER'S MANUAL

Before getting started, check to see that your GARMIN GPSCOM 190 package includes the following items. If you are missing any parts, please contact your dealer immediately.

- GPSCOM 190 Unit
- Flex Whip Com Antenna
- Quick Reference Card
- Owner's Manual
- External GPS Antenna Kit
- Universal Yoke Mount
- Headset/Microphone Adapter
- Trickle Charger/AC Adapter
- Cigarette Lighter Adapter
- Belt Clip
- Carrying Case
- Wrist Strap

CAUTION

The GPS system is operated by the government of the United States, which is solely responsible for its accuracy and maintenance. The system is subject to changes which could affect the accuracy and performance of all GPS equipment. Although the GPSCOM 190 is a precision electronic NAVigation AID (NAVAID), any NAVAID can be misused or misinterpreted and therefore, become unsafe.

Use the GPSCOM 190 at your own risk. To reduce the risk of unsafe operation, carefully review and understand all aspects of this Owner's Manual and thoroughly practice operation using the simulator mode prior to actual use. When in actual use, carefully compare indications from the GPSCOM 190 to all available navigation sources including the information from other NAVAIDs, visual sightings, charts, etc. For safety, always resolve any discrepancies before continuing navigation.

NOTE: This device meets requirements for Part 15 of the FCC limits for Class B digital devices for home or office use. It has been tested for compliance with all necessary FCC standards. This equipment generates, uses, and can radiate radio frequency energy and, if not installed and used in accordance with the instructions, may cause harmful interference to radio communications. However, there is no guarantee that interference will not occur in a particular installation. If this equipment does cause harmful interference to other equipment, which can be determined by turning the equipment off and on, the user is encouraged to try and correct the interference by relocating the equipment or connecting the equipment to a different circuit than the affected equipment. Consult an authorized dealer or other qualified service technician for additional help if these remedies do not correct the problem. Operation is subject to the following conditions: (1) This device cannot cause harmful interference, and (2) this device must accept any interference received, including interference that may cause undesired operation. The GPSCOM 190 does not contain any user-serviceable parts. Repairs should only be made by an authorized service center. Unauthorized repairs or modifications could void your warranty and your authority to operate this device under Part 15 regulations.

Table Of Contents

SECTION ONE Getting Started

Unit Description/Keys and Controls	2-5
Initializing the Receiver/Acquiring Satellites	6-7

SECTION TWO GPSCOM 190 Takeoff Tour

GPS Page Sequence/Frequency Entry	9-10
Simulator Mode/Activating a GOTO	11-12
Basic Page Operation	13-19
Emergency Channel Selection/Auto Zoom	20
Cancel GOTO/Power Off	21-22

SECTION THREE Reference

Waypoint Categories/Nearest Pages	23-32
Communication Pages and Functions	33-42
GOTO/TracBack Navigation	43-46
Routes	47-51
Satellite Status Page	52-53
Position Page/Map Page Functions	54-60
Navigation Page/Main Menu	61-68
Interface Setup and Features	69-70
Setup Menu Options	71-81
Appendix A—Accessories & Installation	82-89
Appendix B—Specifications	90-91
Appendix C—Messages	92-93
Appendix D—Map Datums	94-95
Appendix E—Time Offsets	96
Appendix F—Index	97-99

Unit
Description

BNC Antenna
Connector

Squelch
Control

Volume
Control

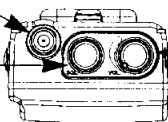

Top View

The GPSCOM 190 combines a 12 parallel channel GPS receiver with a 760-channel digital VHF aviation communications transceiver in a convenient handheld package. Direct data entry and functional control is provided by the alphanumeric and function keys located on the front of the unit (alphanumeric keys are labeled with white numbers and letters, function keys are labeled green). The squelch and power/volume controls are located on the top of the unit. The microphone is located in the lower left speaker area.

Flex Com
Antenna

Internal GPS
Antenna

Alphanumeric
Keypad

Function
Keys

Speaker

Arrow Keypad

Microphone

LCD Display

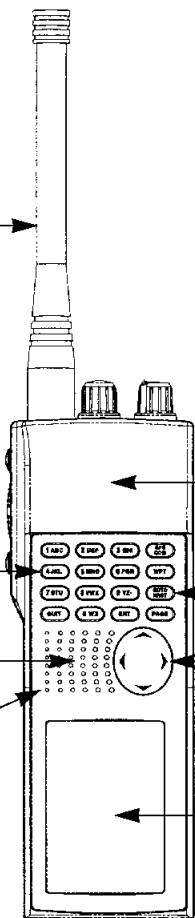

Front View

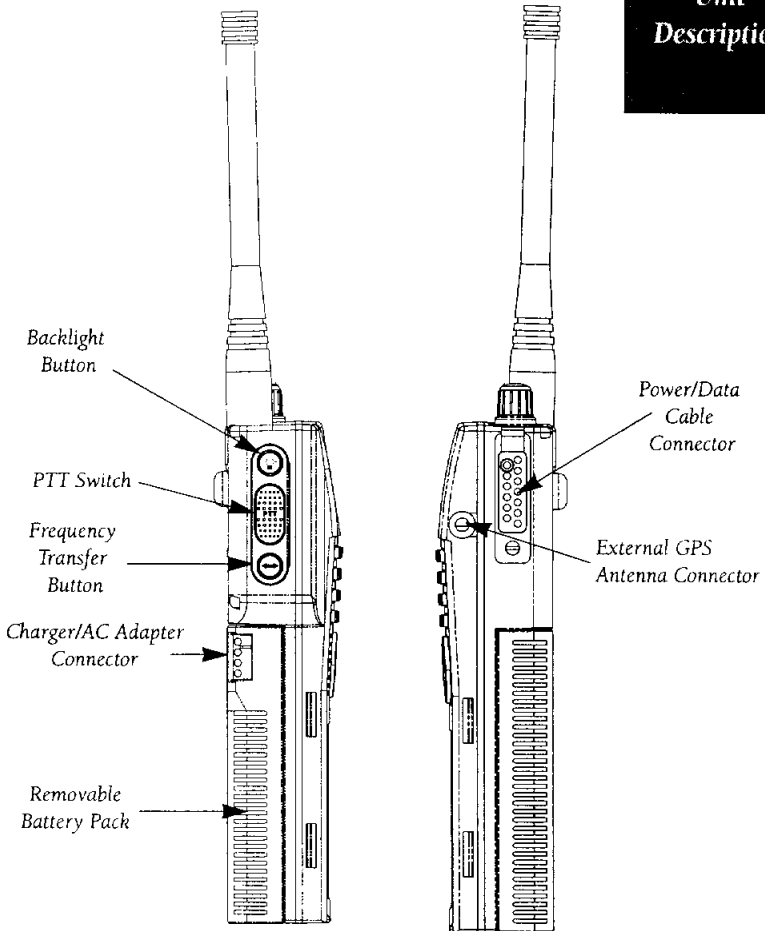
**Unit
Description**

Side Views

The backlight, frequency transfer, and push-to-talk buttons, along with the charger/AC adapter connector are located on the left side of the unit. The connectors for the external GPS antenna and power/data cable are located on the right side. The removable Ni-Cad battery pack is attached to the back of the unit. See Appendix A for instructions on battery pack removal.

Keys and Controls



Use the two-speed **arrow keypad** to enter data. Press on a particular arrow key once to scroll through data options slowly. Press and hold down an arrow key for faster scrolling.



Use the **UP** and **DOWN** arrow keys to select alphanumerical characters and menu choices, and to move the field highlight from field to field.



Use the **LEFT** and **RIGHT** arrow keys to move the selected character field, and to move the highlight from field to field. The left arrow key is also used to clear a selected field.

1 ABC

The **ALPHANUMERIC** keys enter characters into a highlighted field without needing to press **ENTER** to access data entry.

GOTO
NRST

The **GOTO/NRST** key quickly sets a direct course to a selected destination. Pressing **GOTO** twice displays the nearest waypoint page.

WPT

The **WPT** key accesses the GPSCOM 190's internal database of airports, VORs and other waypoints, as well as the AutoStore function.

0 WX

Pressing the **0WX** key enters a zero into a numeric or alphanumerical field. It also places a weather channel into a highlighted standby frequency field.

GPS
COM

The **GPSCOM** key lets you choose between the main GPS and main communication pages. Press and hold the **GPSCOM** key to select the 121.5 MHz. emergency frequency as the active frequency.



PAGE

The **PAGE** key scrolls through the main data pages in sequence and returns the display from a submenu page to a main page. It also displays the message screen when a message alert appears.

ENT

The **ENTER** key confirms data entry and on-screen responses. This key also activates highlighted fields to allow data entry.

QUIT

The **QUIT** key returns you to a previous page, or clears data entry and restores a data field's previous value.



The **FREQUENCY TRANSFER** button flip-flops the active and standby frequencies.



The **SQUELCH** control eliminates receiver background noise and allows only received transmissions to be heard.



The **PUSH-TO-TALK (PTT)** switch activates the GPSCOM 190 transmitter on the active frequency.



The **BACKLIGHT** button illuminates the alphanumeric keys, arrow keypad, and LCD Screen through four levels of backlighting (three levels of brightness and off).



The **ON/OFF/VOLUME** control turns the unit on and off and adjusts the volume level.



Initializing The Receiver

Important!

Make sure you charge the Ni-Cad battery pack for 14 hours before using your GPSCOM 190 to ensure optimum capacity and performance. Note: When charging the battery pack, turn the unit off to ensure a full charge. Complete instructions on charging the pack are given on page 89.



Welcome Page

Initializing the GPSCOM 190 for First-Time Use

The first time you power up your new GPSCOM 190 is an important step in getting the best possible GPS performance. **The receiver must be given an opportunity to collect satellite almanac data and establish its present position.** This initialization process takes approximately 3 to 5 minutes and is only necessary for first time operation, after memory loss, or when the receiver has been moved more than 500 miles from the last calculated position with the power off. Once your GPSCOM 190 has been properly initialized, you should acquire satellites and obtain a position quickly each time you power up.

Your GPSCOM 190 is shipped in the AutoLocate mode, which is designed to let the receiver "find itself" without using its last known position (you don't need to worry about what lat/lon is currently displayed on the position page, as the unit is not using that information to calculate your present position.)

To power up your unit for first time use:

1. Position the internal GPS antenna so it has the best possible view of the sky (the internal patch antenna is located just above the keypad, marked by the embossed globe.) If necessary, see Appendix A for instructions on the installation of the GA 27 external GPS antenna.
2. Turn the unit on by rotating the volume control clockwise.
3. Rotate the squelch control clockwise until receiver noise disappears.
4. Remain in the same location until the GPSCOM 190 has calculated a position (the status page will be replaced by the position page if no other buttons have been pressed during acquisition).

Welcome Page and Database Configuration

The welcome page will be displayed while the unit conducts a self test. Once testing is complete, the welcome page will be replaced by the database page (see the top of page 7), showing the database issue date. Updates to the database are available from GARMIN or Jeppesen on a subscription or one time basis.

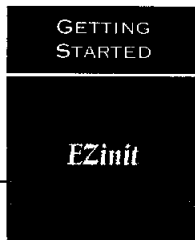
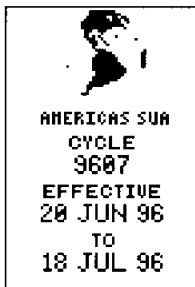

EZinit

After a few seconds, the status page will appear with the EZinit prompt ready for you to select one of two initialization methods:

- Select Country— allows you to initialize the receiver by selecting your present position from a list of countries in the GPSCOM 190's internal database. This feature provides a position fix in 3-5 minutes.
- AutoLocate— allows the GPSCOM 190 to initialize itself and calculate a position fix without knowing your present position. This feature provides a position fix in approximately 5 minutes.

If the EZinit prompt has not automatically appeared on the status page, press **ENT**.

If you've already initialized the GPSCOM 190 and the EZinit prompt appears, highlight the 'NO RE-INIT' selection with the arrow keypad and press **ENT**. The EZinit prompt may appear if you've had the unit on in normal mode while indoors, or if the antenna is shaded while acquiring satellites.

To initialize the receiver:

1. Use the up or down arrow keys to highlight the 'COUNTRY' option and press **ENT**.
2. Use the down key to scroll through the country listings until the country where you are presently located appears.
3. Use the up or down arrow key to highlight the country/state/region you're in. If the country you're in is not listed, select another country within 500 miles of your present position.
4. Press **ENT** to finish.

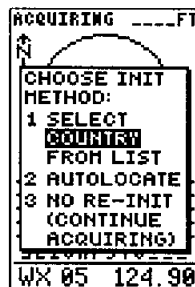

The EZinit prompt will automatically appear if the receiver needs to be initialized. The prompt may also appear during normal use if the antenna is shaded or the unit is indoors.



If necessary, use the arrow keypad to highlight the country and region or state of your present position from the list and press ENTER. If the country is not listed, select the closest country, region or state instead.

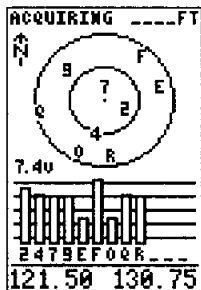

Acquiring
Satellites

Once satellites have been found, hollow signal strength bars will be displayed while data is being collected. The signal strength bars can be used to help determine if satellites are being shaded.

Acquiring Satellites

The GPSCOM 190 will now begin searching for the appropriate satellites for your position and should acquire a fix within three to five minutes. Verify getting a position fix by watching the status page transition to the position page (provided you haven't pressed any other keys) or by looking for a '2D NAV' or '3D NAV' status at the top-left corner of the status page.

If you have trouble initializing the receiver or getting a position fix, check the following:

- **Does the antenna have a clear view of the sky?**

If there are large buildings such as hangers, metal surfaces, or other obstructions, the unit may not be receiving enough satellite signals to calculate a fix.

- **Is the right country/state selected from the EZinit list?**

Check for the correct approximate lat/lon on the position page or reselect the appropriate country from the list to restart the initialization.

- **Have you moved more than 500 miles from the last calculated position with the receiver off?**

Reinitialize the receiver, selecting the country/state of your new location from the EZinit list.

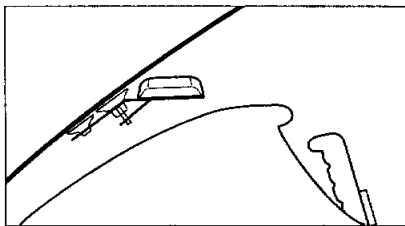
Remote Antenna Installation

If your installation does not provide an adequate view of the sky, install the remote antenna included with your unit. See page 86 for installation instructions.

GPSCOM 190 Takeoff Tour

The takeoff tour is designed to quickly guide you through basic features and functions of the GPSCOM 190 using a simulated trip.

Once you've completed the tour and become familiar with the main pages and features of the unit, refer to the reference section for complete instructions on installation and performing specific tasks and functions.

The takeoff tour assumes you have initialized the unit and have not changed any of the default settings. If you have changed any settings, the descriptions and pictures used may not match your configuration. You're now ready to power up and take off.

To turn the unit on:

1. Rotate the power/volume knob clockwise.
2. Turn the squelch knob counterclockwise until the receiver background noise disappears.
3. After the unit performs a self-test, the database information page will appear, listing the date of the aviation database.

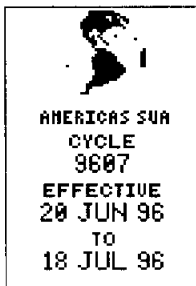

The database page reflects the worldwide database of airports and VORs contained in the GPSCOM 190. Database updates and subscriptions are available from GARMIN and Jeppesen. After a few seconds, the database information page will be replaced with the satellite status page. The status page provides a visual reference of satellite acquisition and status, with signal strength bars and a satellite sky view in the center of the screen.

TAKEOFF
TOUR

Power On

Important!

The takeoff tour assumes you are using an Americas database. If you are using an Atlantic International database, try simulating a flight from EGLC to EGSR. For a Pacific International database, try flying PHDH to PHNG.

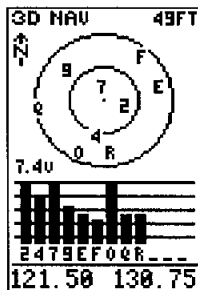

Use the status page to instantly view satellite usage and current signal strength.

Page Sequence

Scrolling Through the Main GPS Pages

The GPSCOM 190 features five main GPS pages in a continuous loop: satellite status, position, map, navigation, and main menu. Try scrolling through the pages by pressing **PAGE**. You can also scroll in the opposite direction (or return to a previous page) by pressing **OUT**.

Status Page

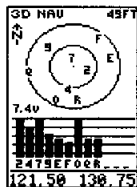

Position Page

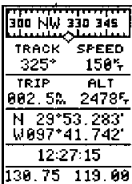

Map Page

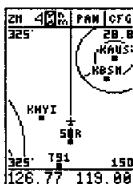

Navigation Page

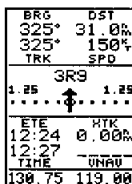

Menu Page



Frequency Entry - GPS Pages

During the course of navigating with the GPSCOM 190, there may be times when you'll want to quickly enter a frequency from a GPS page. The GPSCOM 190 will always display the active and standby frequencies at the bottom of every GPS page. The standby frequency is displayed on the right side of the page and the active frequency on the left.

To enter a frequency from any GPS page:

1. Use the arrow keys or press **GPS COI** to highlight the standby frequency field.

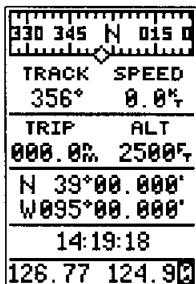

Entering a com frequency from the position page.

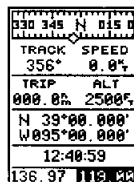
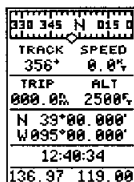

GPS COI

The starting position of our simulated flight is Lockhart Municipal Airport (50R, the ICAO identifier), in Lockhart, Texas. Before we begin, let's practice alphanumeric data entry by entering the tower frequency for Lockhart Municipal, which is 124.90 MHz.

1. Press the button labeled **1 ABC**.
2. Press **2 DEF**.
3. Press **4 JKL**.
4. Press **9 YZ-**.
5. Press **0 WX**.
6. Press **ENT** to confirm.

If an incorrect number is selected during entry:

1. Use the arrow keys to move away from the incorrect character and then back to it.
2. Enter the correct character.
3. Press **ENT** to confirm.

To place the standby frequency in the active frequency field:

1. Press the frequency transfer button on the side of the receiver.

To transmit on the active frequency:

1. Press the PTT switch.

Simulator Mode

To continue the Takeoff Tour, you'll need to put the GPSCOM 190 in simulator mode:

1. Press **PAGE** repeatedly until the main menu page appears.
2. Use the up or down arrow keys to move the field highlight to the 'SETUP MENU' option and press **ENT**.
3. Highlight the 'Operation Mode' field and press **ENT**.
4. Highlight the 'Current Mode' field and press **ENT**.
5. Use the arrow keys to toggle through the options until you reach 'Simulator' and press **ENT**.

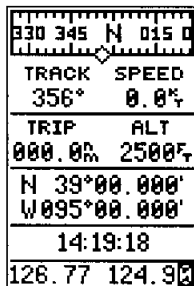
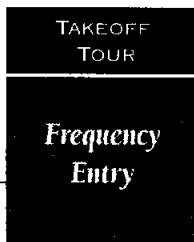

Entering the tower frequency for the starting position of the simulated flight, 124.90 MHz.

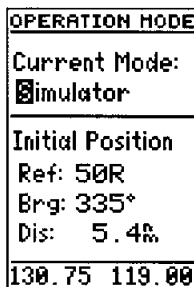

Putting the GPSCOM 190 in simulator mode.



Activating a GOTO

OPERATION MODE	
Current Mode: Simulator	
Initial Position	
Ref: 50	---
Brg: 000°	
Dis: 0.0%	
129.65	133.57

Entering the initial starting position of 50R.

GO TO:
3R9---
- PRESS ENTER TO ACTIVATE NAVIGATION
- PRESS GOTO TO SEE NEAREST WAYPOINTS/SUA
130.75 119.00

Entering the destination waypoint, 3R9.

The field highlight will move to the initial position field, where you can enter the starting position of our simulated flight, Lockhart Municipal Airport (50R, the ICAO identifier), in Lockhart, Texas:

1. Press **5 UNO**. Press the up arrow key twice to select '5'.

Note: When entering waypoint identifiers, the GPSCOM 190's will scroll through the available database, displaying any waypoints with the same letters you have entered to that point.

2. Press **0 VIX**.
3. Press **6 POR**. Use the up arrow key to select 'R'.
4. Press **ENT** to confirm the selection.

If an incorrect character is selected during entry:

1. Use the arrow keys to move away from the incorrect character and then back to it.
2. Enter the correct character.
3. Press **ENT** to confirm.

Since we'll be taking off from the airport, keep the position and bearing values at zero to keep our position located at the airport.

To return to the main menu page:

1. Press **QUIT** twice.

Activating a GOTO

Once you have entered the starting position of your flight, the next step is to select your GOTO destination, Lakeway Airport (3R9), in Austin, Texas.

1. Press **GO TO
NRST**.
2. The GOTO page will appear with the identifier field ready to accept changes.
3. Use the alphanumeric keys to enter the identifier of the destination waypoint (3R9). (Remember to use the arrow keypad to select the desired character from each alphanumeric key.)
4. Press **ENT** to confirm your destination and activate the simulated navigation.

Navigation Page

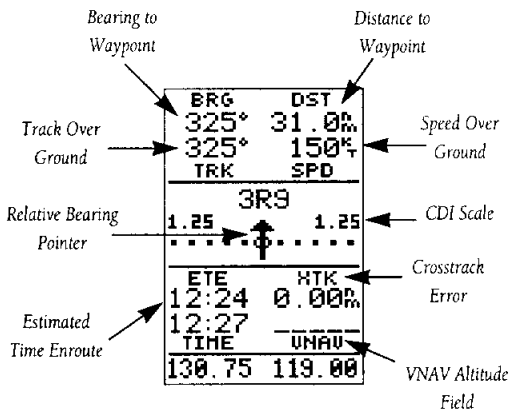

Once a GOTO is activated, the navigation page will display the bearing and distance to the destination, along with your present speed and track over ground. The GOTO destination is listed above the course deviation indicator, with your estimated time enroute, cross track error and time displayed at the bottom of the page. A relative bearing pointer, located above the CDI scale, points to the direction of your destination.

Simulated Speed Entry

Now you'll need to enter a speed for the aircraft:

1. Highlight the 'SPEED' field.
2. Press **FABC** and **5HND** to enter a speed of 150 knots.
3. Press **ENT** to confirm the speed.

Once a speed has been entered, the navigation page will continuously update as we make our way to the destination airport. We now need to enter the cruising altitude of our flight, which can be entered from the position page:

1. Press **PAGE** until the position page appears.
2. Move the field highlight to the 'ALT' field.
3. Enter an altitude of 2,500 feet and press **ENT** to confirm.

TAKEOFF
TOUR

Navigation
Page

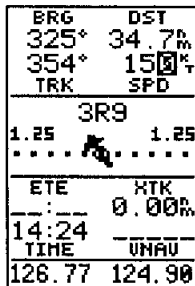

In simulator mode, speed may be entered from the navigation page speed field. **NOTE:** Never use simulator mode for actual navigation.

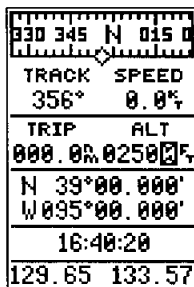

Entering an altitude of 2,500 feet on the position page.

TAKEOFF
TOUR

Position & Map Page

030 345 N 015 0
TRACK SPEED
356° 150%
TRIP ALT
000.0% 2500%
N 39°00.344'
W 095°00.000'
12:41:40
136.97 119.00

The position page also features a resettable trip odometer to keep track of your distance traveled. The trip odometer may be reset to measure your distance traveled.

Position Page

The GPSCOM 190 position page displays your present latitude, longitude and altitude, along with your current track and speed over the ground. The top of the page also features a graphic heading indicator, which displays your cardinal heading as you're moving. The time of day, displayed in UTC or local time, is indicated near the bottom of the page above the standby and active frequency fields.

Most of your in-flight navigation with the GPSCOM 190 will center around the navigation and moving map pages. Now that we're on our way, let's move on to the map page by pressing **PAGE**.

Moving Map Page

The GPSCOM 190's moving map page provides extensive capabilities and information on your present position, nearby facilities and waypoints, and your active route. Let's zoom in for a closer look at our progress:

1. Highlight the zoom field (it may be already be highlighted) and press **ENT**.
2. Press the down arrow key once to change the scale to the 40nm setting, and press **ENT** to confirm.

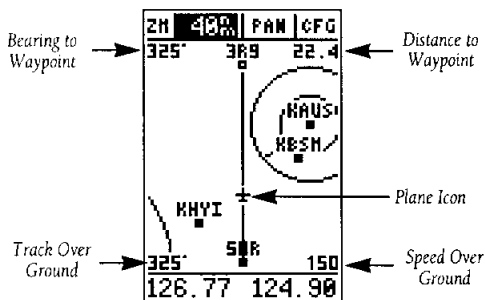

At the 40nm scale, you'll be able to see your plane and nearby airports. The line up the center of the page represents the track-up route from your starting point (50R) to the destination airport (3R9), with your present position indicated by the plane icon. Notice that your plane remains centered on the map, while nearby waypoints pass relative to your present speed and track.

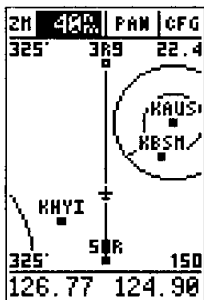
Moving Map
Page

The moving map page can be broken down into three parts: the **zoom, pan and configuration fields**, located at the top of the page; the **moving map field**, and the **track and speed fields**, which are located in the bottom corners of the map. The zoom and pan fields provide access to the map scale and scrolling cursor functions. The configuration field allows you to determine which items are displayed on the screen, while the map field lets you highlight on-screen airports and waypoints for immediate review. The speed and track fields are display fields only, and do not provide access to other functions.

The default placement of the cursor highlight is on the zoom field. To move the cursor to the pan field or through the on-screen waypoints, simply use the arrow keypad to move in the desired direction, and press **ENT** to activate the function or review the selected waypoint. Try selecting KAUS, just right of our current route, to practice:

1. With the field cursor on the zoom field, press the down key until the KAUS identifier field is highlighted.
2. Press **ENT** to review the waypoint location page for KAUS.

The waypoint location page for KAUS will appear, providing you with the facility's name and location (city/state/region), with the elevation, latitude and longitude of the field, and fuel available (AV, Jet or Mogas). In addition to the location page, each airport in the GPSCOM 190's database feature separate communication and runway pages, which are accessible from the prompts located near the bottom of the location page.

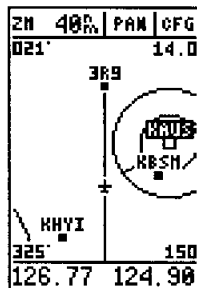

Use the **ARROW KEYPAD** to select on-screen waypoints by moving the cursor onto the waypoint name.

Whenever a waypoint identifier is highlighted, pressing enter will allow you to review its waypoint page.

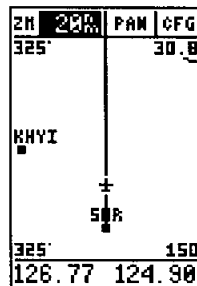

Zooming in to lower scales will show fewer waypoints and make the screen less crowded.

Airport Pages
& SUAs

HAYPOINT	
AFT:	3R9
1 UNCH	123.00
2 DE	STANDBY?
3 AP	MEMORY?
LOGN?RHHY? DONE?	
130.75	119.00

Selecting a frequency on the airport communication page for placement in the standby frequency field.

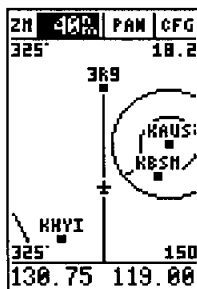

The GPSCOM 190's sectorized boundaries let you watch your proximity to the boundaries on the moving map.

To view the airport communication page for KAUS:

1. Use the left arrow key to highlight 'COM?' and press

ENT.

All of the available frequencies for the selected airport will be displayed, with the designation shown at the left of each frequency. If there are more than seven frequencies for a selected airport, use the down arrow key to view additional frequencies. From the list, you can also select a frequency and place it in the standby frequency field:

1. Use the arrow keypad to select the desired frequency.
2. Press **ENT**. The 'STANDBY?' prompt will be highlighted.
3. Press **ENT**. The frequency is now placed in the standby frequency field.

To view the runway information page:

1. Press **ENT** repeatedly until the runway information page is selected.

The runway information page features a diagram of the available runways, along with runway length, surface type and lighting for each runway.

To return to the moving map page:

1. Move the field highlight to the 'DONE?' prompt and press **ENT**.

Once you're back on the moving map page, you'll notice that our plane is getting close to the special use airspace surrounding KAUS.

Whenever you are within 2 nm of an SUA, projected to enter an SUA or inside an SUA, the GPSCOM 190 will notify you with a message and supply detailed information on each SUA you are being alerted to. By looking closely at the map display, you'll notice that we will come very close to the KAUS SUA, but not actually enter it. Once our flight takes us within 2 nm of the SUA, we'll be alerted with a 'Near SUA < 2nm' message (you may have to wait a minute or so to get the message, depending on how fast you've made your way through the tour.

To view the SUA message:

1. Press **PAGE**.

To return to the map page, press **PAGE** again.

Additional information, including the name, class, controlling agency and altitudes, is available from the **GOTO NRST** key. To view additional SUA information:

1. Press **GOTO NRST** twice. The nearest SUA alarm page will appear, which can display up to 9 SUA alerts at once. Each listing will display the type of alert and your ETE to intrusion, if applicable.
2. To view specific information on any listed SUA, highlight the desired SUA name and press **ENT**.

The SUA page will appear, providing additional information on floor and ceiling altitudes for the selected SUA.

3. To return to the nearest SUA list, press **ENT**.
4. To return to the map page from the SUA list, press **QUIT**.

Alert messages for the various classes of SUAs may be turned off to avoid nuisance alerts, and may also be removed from the map to avoid excess clutter at higher map scales. For complete information and definitions on SUAs, see page 73.

Nearest Waypoints Page

The nearest waypoints page displays the nine nearest airports, VORs, NDBs, INTs, and user waypoints to your present position, and is extremely useful for locating the nearest facility during an in-flight emergency. In addition, nearest flight services stations (FSS), Air Route Traffic Control Centers (ARTCC), and special use airspace alarms can also be viewed.

To view the nearest waypoints of a particular category, you need to select the desired category from the category field at the top of the nearest page. Let's practice by viewing the nearest airports to our present position:

1. Press **GOTO NRST** twice to display the nearest page.
2. Press **ENT** to begin selection of the desired category.
3. Scroll through the waypoint categories until 'APT' appears in the category field.
4. Press **ENT** to confirm the category. The field highlight will move to the first facility on the list.

TAKEOFF
TOUR

Nearest Waypoints Page

NRST	ALRM	SUA
1	AUSTIN	
	NEAR < 2 nm	
2	-----	
3	-----	
	130.75	119.00

The nearest SUA page provides information about special use airspace alerts.

NEAREST	APT	
WAYPNT	BEG	DIST
KHYI	202'	9.09
KBSH	022'	11.5
SOR	145'	12.1
KAAUS	009'	16.8
T91	154'	19.1
3R9	325'	22.7
3R5	209'	23.7
T90	197'	28.4
B3R	175'	30.0
	130.75	119.00

The bearing and distance to the nine nearest airports may be quickly accessed on the nearest airport page for use in an emergency or for general information.

Com Page Sequence

NEAREST VOR		
WAYPNT	BRG	DIS
LOA	055°	114
IAH	090°	133
AQM	359°	135
HQP	352°	152
TQA	315°	158
SCY	024°	158
F2T	041°	166
DFW	009°	167
ABI	318°	171
126.77	124.90	

Information on the nine nearest VORs is also available on the VOR page.

Once you've selected and confirmed a category, the GPSCOM 190 will display the nine nearest facilities and provide the distance and bearing to each waypoint in the list. To scroll and review the nearest waypoints list:

1. Highlight the desired waypoint.
2. Press **ENT** to review the waypoint page(s).
3. Press **ENT** again to return to the nearest list. The field highlight will sequence to the next waypoint on the list.
4. Press **QUIT** to exit the nearest function and return to the previously viewed page.

Communication Page Sequence

Let's continue the tour and look at the pages that control the communications features of the GPSCOM 190. Press **GPS COM** twice to exit the GPS pages and enter the com pages.

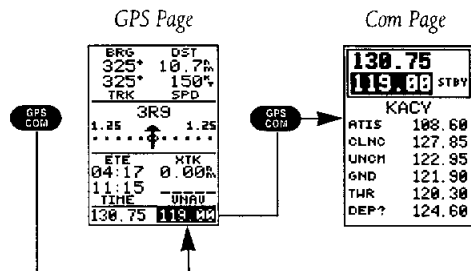

The GPSCOM 190 features three com pages in a continuous loop. Try scrolling through the pages by pressing **PAGE**. You can also scroll in the opposite direction (or return to a previous page) by pressing **QUIT**.

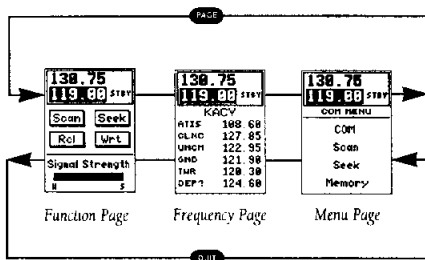

The active and standby frequency fields appear at the top of every com page. These fields allow you to enter a frequency using the alphanumeric keys.

To enter a frequency from any com page:

1. If you haven't done so yet, press **GPS COU** twice to enter the com pages from the GPS pages.
2. Highlight the 'STBY' frequency field.
3. Enter the desired frequency.
4. Press **ENT** to confirm. The frequency you entered is now the standby frequency. Press the frequency transfer button to place it in the active field.

The next available com page is the com frequency page. The com frequency page gives you a complete list of airport frequencies at the departure and arrival airports, allowing convenient selection of frequencies you'll need along your flight path. If you do not have an active departure airport, the com frequency page will display the frequencies for the airport nearest your present position. If all of the frequencies are not visible, use the arrow keys and scroll down.

At this point in the flight you'll probably want to select the destination airport approach control frequency.

To select a frequency from the com frequency page:

1. Press **PAGE** repeatedly until the com frequency page appears.
2. Use the arrow keys to highlight the approach frequency for 3R9, 119.00 Mhz.
3. Press **ENT**. The standby prompt is highlighted.
4. Press **ENT**. The 119.00 MHz frequency will move to the standby frequency field marked 'STBY'.

To place 119.00 MHz in the active field:

1. Press the frequency transfer button.

TAKEOFF
TOUR

Nav Frequency List

130.75	
119.00	STBY
50R	
UNCH	122.80
DEP	124.90
3R9	
APP	119.00
UNCH	123.00

Selecting a frequency from the com frequency page.

119.00	
129.65	STBY
KACY	
ATIS	108.60
CLNC	127.85
UNCH	122.95
GND	121.90
THR	120.30
DEP?	124.60

The frequency of 119.00 MHz placed in the active field.

Emergency Channel Selection

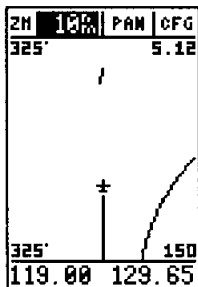

AutoZoom at the 10 nm scale.

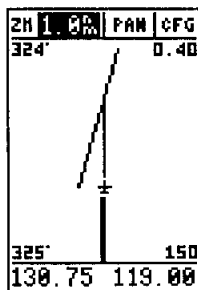

AutoZoom at the 1 nm scale.

Emergency Channel Selection

The GPSCOM 190's emergency channel selection feature provides a quick method of selecting 121.5 MHz as the active frequency in the event of an in-flight emergency. The feature is available whenever the unit is on, regardless of GPS or communication status, or unexpected loss of the display.

To select the 121.5 MHz frequency as the active frequency:

1. Press and hold .



To transmit on the emergency frequency:

1. Press the PTT switch.

Now let's go back to the map page and finish up our tour:

1. Press  to enter the GPS pages.

Auto Zoom

You will notice that as we make our way toward the destination airport, the map scale will automatically zoom in to provide a closer look at the airport. What you're actually seeing is the GPSCOM 190's AutoZoom feature. Whenever you select a GOTO destination, the map page will default to the 80 nm setting and gradually zoom down the map scale to the 1 nm setting.

The map scale will zoom to the next lowest setting (i.e., from 80nm to 40nm) whenever the map can fit both your present position and your destination on the screen.

If you manually zoom in the map scale before this point, the AutoZoom feature will resume once it catches up to the map scale you have selected (down to 1nm).

If the map is manually zoomed out beyond the AutoZoom scale, the AutoZoom will be canceled, and the GPSCOM 190 will assume you want to stay at the scale you have manually selected.

Canceling GOTO Navigation

By now, our plane should be approaching 3R9, the destination airport. The map will continue to zoom down to the 1nm scale. To finish the tour and complete our approach, let's move back to the navigation page:

1. Press **PAGE** to display the navigation page.

Once we fly past the airport, notice that the GPSCOM 190 continues to provide navigation to 3R9, with the relative bearing pointer and ETE fields indicating we are past our destination. The GOTO destination may be canceled by activating another GOTO or canceling the current GOTO.

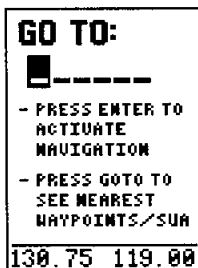

To cancel the current GOTO:

1. Press **GOTO**.
2. Press the left arrow key once to clear the destination field (pressing the left arrow key clears a selected field when the cursor is in the left most character position.)
3. Press **ENT** to confirm.

TAKEOFF
TOUR

Cancel GOTO

GO TO:

[]-----
- PRESS ENTER TO
ACTIVATE
NAVIGATION
- PRESS GOTO TO
SEE NEAREST
WAYPOINTS/SUA

130.75 119.00

Cancel GOTO

Use the LEFT ARROW key to cancel GOTO navigation and press ENTER to confirm.

Power Off

Power Off

Congratulations! You've now mastered some of the basic features of the GPSCOM 190 and you're ready to take off with a powerful tool that can help make your flights smoother and more efficient.

To turn the GPSCOM 190 off:

1. Turn the volume control counterclockwise.

Thank you for choosing the GARMIN GPSCOM 190. We hope it will be a valuable navigation and communication tool for you, wherever your course may take you.

Be sure to carefully review the sections on installation and the internal database so you can get the most out of your new GPSCOM 190. The takeoff tour has only explored a small part of what this unit can do for you. The reference section will describe in detail all of the GPSCOM 190's functions and features.

Waypoint Categories

Internal Database

The GPSCOM 190 uses an internal Jeppesen® database to provide position and facility information for thousands of airports, VORs, NDBs and intersections. Each facility in the database is stored as a waypoint, with its own latitude/longitude, identifier (up to six letters and/or numbers) and other pertinent information. There are three database coverage areas available for the GPSCOM 190. They are referred to as the "Americas", "Atlantic International", and the "Pacific International" databases.

The International Civil Aviation Organization (ICAO) and Aeronautical Radio, Inc. (ARINC) break the world into ten geographic regions. The GPSCOM 190 Americas database contains aeronautical information for the group of ICAO regions consisting of North, Central, and South America. The 'Atlantic International' database provides information for the ICAO regions of Europe, Africa, Eastern Europe, and the Middle East. The Pacific International database gives information for the ICAO regions of Eastern Europe, Middle East, Pacific, and South Pacific.

Waypoint Categories

Five categories of waypoint information are available through the **WPT** key. Each category provides different types of detailed information for a selected facility:

- **Airports**— Identifier, city/state, country, facility name, position (lat/lon), elevation, fuel services, runways, and communications frequencies.
- **VORs**— Identifier, city/state, country, facility name, position (lat/lon), frequency and co-located DME or TACAN availability.
- **NDBs**— Identifier, city/state, country, facility name, position (lat/lon) and frequency.
- **Intersections**— Identifier, region/country, position (lat/lon) and range/bearing to nearest VOR.
- **User**— Identifier (name), position (lat/lon), user comments and reference waypoint.

To view the waypoint information for a desired waypoint, select the waypoint category from the category field, located at the top left of the waypoint page, next to the identifier field.



**AMERICAS SUA
CYCLE
9607
EFFECTIVE
20 JUN 96
TO
18 JUL 96**

The GPSCOM 190's internal Jeppesen database is available with an Americas, Atlantic International, or Pacific International database. The database cycle is displayed on the database information page. Information on updating the database is included with your GPSCOM 190 package.

Entering Waypoint Identifiers

WAYPOINT	
APT: 50	---
LOCKHART NUM	
LOCKHART TX	
ELEV 530FT	
N 29°51.043'	
W 097°40.334'	
FUEL AV JET	
RNVY? COMN? DOME?	
130.75	119.00

Entering a waypoint identifier.

WAYPOINT	
APT: KAUS	
QUELLER_NUM	---
AUSTIN TX	
ELEV 530FT	
N 30°17.915'	
W 097°42.095'	
FUEL AV JET	
RNVY? COMN? DOME?	
130.75	119.00

Entering a waypoint by facility name.

To choose a waypoint category:

1. Press **WPT** to display the waypoint page.
2. Highlight the category field.
3. Press **ENT** to begin selection of the waypoint category.
4. Use the arrow keys and select the desired category.
5. Press **ENT** to confirm the category selection.

Entering Identifiers

After a waypoint category is selected, information for a waypoint can be viewed by entering the identifier or name of the desired waypoint. Airports, VORs, and NDBs may be entered by either the identifier, name, or the location (city) of the facility. Intersections and user waypoints must be entered by the identifier.

To enter a waypoint identifier:

1. Highlight the identifier field.
2. Enter the desired identifier and press **ENT**.

Note: As the identifier is entered, the GPSCOM 190 will scroll through the available database, displaying any waypoints with the same identifier letters you have entered to that point. Once the desired waypoint is displayed, press **ENT**.

After you've selected a waypoint category, waypoint information can also be retrieved by entering the facility name of the airport, the name of the VOR or NDB, or their city name (intersections and user waypoints cannot be retrieved by facility or city name).

To select a waypoint by facility or city name:

1. Select the desired waypoint category (APT, VOR or NDB).
2. Highlight the facility name or city name field.
3. Enter the name of the facility or city and press **ENT**.

Once a waypoint category and identifier have been selected, the GPSCOM 190 will provide extensive information through various waypoint review pages.

Airport Information

HAYPOINT	HAYPOINT	HAYPOINT
APT: KAUS HUELLER NUM AUSTIN TX	APT: KAUS 1 ATIS 119.20 2 CLNC 125.50 3 GND 121.90 4 TWR 121.00 5 UNCH 123.00 5 DEP? 118.80 7 DEP? 119.00	APT: KAUS RUNWAY: LENGTH 07-35 5000FT
ELEV 630FT N 30°17.915' W 097°42.095'		SURFACE LIGHTING HARD FULL TIME
FUEL AU JET RNNY? COMM? <u>000.00</u>	LOGN? <u>0.00</u> DONE?	COMM? LOGN? DONE? 130.75 119.00

Location Page

Communication Page

Runway Page

Airport
Information

The GPSCOM 190 features three airport pages:

- **Airport location**— allows entry of desired airport by identifier, facility name or city and displays latitude, longitude and elevation; and fuel availability.
- **Airport communication**— allows entry of desired airport by identifier and displays radio frequencies/usage.
- **Airport runway**— allows entry of desired airport by identifier, displays runway designations, length, surface and lighting information, and/or pilot controlled lighting frequencies.

To scroll through the airport pages:

1. Select the airport category and enter the desired airport identifier. The airport page initially displayed will be the same as the last airport page viewed.
2. Use the left arrow key to move the field highlight to the desired page prompt and press **ENT**.

Once you have moved from the initial airport page displayed, the page prompt will automatically move forward to the next available prompt. This allows you to continuously cycle through the airport pages by simply pressing **ENT** repeatedly.

To exit the airport pages and return to the previously viewed page:

1. Press **QUIT**.

HAYPOINT
APT: KLAX LOS ANGELES INTL
LOS ANGELES CA
ELEV 130FT N 33°56.556' W 118°24.484'
FUEL AU JET
RNNY? COMM? <u>000.00</u>
126.77 124.90

The internal database uses ICAO identifiers for all airport names. All U. S. airports which contain only letters use the prefix 'K'. For example, Los Angeles International is KLAX under the ICAO standard.

Other airports, such as Otten Memorial (3VS), that contain numbers in the identifier, do not require the 'K' prefix. Many countries outside the U. S. use two letter prefixes. For more information, contact the international Civil Aviation Organization.

Airport Location Page

WAYPOINT	
APT: KAUS	
1 ATIS	119.20
2 CLNC	125.50
3 GND	121.90
4 TWR	121.00
5 UNCH	123.00
6 DEP?	118.80
7 DEP?	119.00
LOCM? <input type="checkbox"/> <input checked="" type="checkbox"/> <input type="checkbox"/> DONE?	
130.75	119.00

In some instances, all available frequencies for a selected airport may not fit on the communication page. Use the DOWN ARROW key to scroll through and view any additional frequencies. In addition to the frequencies already mentioned, the following frequencies are also displayed if available:

- Pre-Taxi
- Clearance Delivery
- Approach
- Departure
- Arrival
- Class B and C
- CTA
- TMA
- TRSA

Location Page

WAYPOINT	
APT: KAUS	Identifier Field (selectable)
HUELLER NUM	
AUSTIN TX	City/State (selectable)
ELEV 630FT	Elevation & Position
N 30°17.915'	
W 097°42.095'	
FUEL AV JET	Available Fuel Types
RNAV? COMM? <input checked="" type="checkbox"/> <input checked="" type="checkbox"/>	
130.75 119.00	

The GPSCOM 190's airport location page displays the latitude, longitude and elevation of the selected airport, as well as fuel availability. From the airport location page, you can enter a desired airport by identifier, facility name or city as described on page 24. The following descriptions and abbreviations are used on the airport position page:

- Elev— Elevation in feet or meters
- Position— In the position format you have currently selected from the setup page
- Fuel— Lists the types of fuel available at the airport:
 - AV gas— 80-87 octane, 100 LL, 100-130 octane
 - JET— Jet A, Jet A-1 or Jet A+
 - MOGAS— 87 octane unleaded

Airport Communication Page

The airport communication page (shown in the left margin) displays radio frequencies and their usage for the selected airport, and allows entry of a desired airport by identifier only. The following frequencies are displayed if available (see left margin for additional frequencies):

- ATIS— Automatic Terminal Information Service
- Grnd— Ground
- Twr— Tower
- Uncom— Unicom/Multicom

Runway Page

Runway Page

The last airport page is the runway page, which features a diagram of available runways, along with designations, length, surface and lighting information for the selected airport.

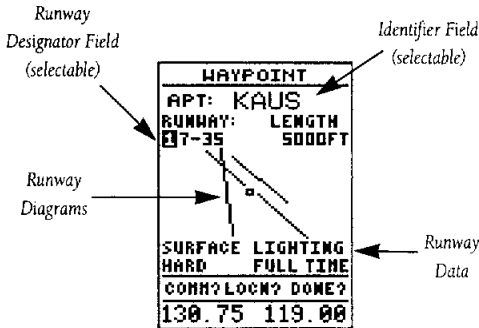

The runway diagram provides a north-up graphic of available runways, with length, surface and lighting data listed below the runway designation. The 'SURFACE' field will display one of the following surface types: hard, turf, sealed, gravel, dirt, soft, unknown or water. The 'LIGHTING' field will indicate one of five lighting schemes: part time, full time, pilot controlled (with frequency), no lighting or unknown.

If a selected airport has more than one runway, additional runways can be viewed by selecting another runway from the designation field.

To view additional runways:

1. Highlight the runway designation field.
2. Press **ENT**.
3. Use the arrow keypad to toggle through and select the desired runway.
4. Press **ENT** to return the cursor to the 'DONE?' prompt.

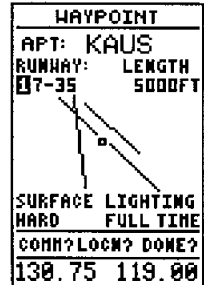

Additional runways are accessed through the runway designation field.

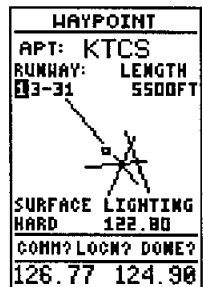

Pilot-controlled lighting with listed frequency.

**Intersections,
NDBs & VORs**

WAYPOINT	
INT: AADCO	
N 45°17.097'	
W 093°12.460'	
REF: GEP	
BEARING	DISTANCE
038°	10.9%
N GEN USA	00000
126.77	119.00

Intersection Page

WAYPOINT	
NDB: AM	
PICNY	
TAMPA FL	
388.0KHz	
N 27°51.680'	
W 082°32.757'	
SE USA	00000
126.77	119.00

NDB Page

Intersection Information

The intersection waypoint page allows entry of a desired intersection by identifier, and displays position and nearest VOR data for a selected intersection.

To view waypoint information on an intersection:

1. Select the intersection category from any waypoint field.
2. Enter the identifier of the desired intersection and press **ENT**.

The unit will display the intersection's latitude and longitude below the identifier field, and calculate the bearing and distance to the nearest VOR. Note that the displayed VOR may not be the VOR used to define the intersection. The region and country of the intersection will also be displayed at the bottom of the page to help you confirm the location in the event of duplicate identifiers.

NDB Information

The NDB waypoint page allows you to select a desired NDB by entering the identifier, facility name or city. In addition to displaying the identifier, facility name and city/state of the NDB, the NDB page will show the latitude and longitude of the facility, the region/country, and the com frequency.

To view waypoint information on a NDB:

1. Select the NDB category from any waypoint category field.
2. Enter the identifier, facility name (on the second line) or city (on the third line) of the desired NDB and press **ENT**.

VOR Information

The VOR waypoint page allows you to enter a VOR by identifier, facility name, or city name and displays the selected facility's position, frequency and other information.

To view waypoint information for a VOR:

1. Select the VOR category from any waypoint category field.
2. Enter the identifier, facility name or city of the desired VOR and press **ENT**.

The VOR page lists the identifier, facility name and city/state of at the top of the page, with the transmitting frequency of the facility listed below. If DME or TACAN equipment is co-located at the site, it will be indicated next to the transmitting frequency of the VOR. The latitude and longitude is also displayed, with the region and country indicated near the bottom of the page.

User Waypoint Information

The last waypoint category available from the GPSCOM 190's WPT key is user waypoints. The user waypoint page allows entry of a desired waypoint by name/identifier and displays the waypoint's position, user comments and a reference waypoint field to calculate the distance and bearing to any other waypoint in the database. The user waypoint page can also be used to create up to 250 waypoints by manually entering a position or defining a range and bearing from an existing waypoint.

To view waypoint information for a user waypoint:

1. Select the **USR** category from any waypoint category field.
2. Enter the identifier/name of the desired user waypoint.
3. Press **ENT**.

The user waypoint page allows you to create new waypoints three ways:

- Enter the exact position of the new waypoint.
- Reference a waypoint already in the database.
- Enter a distance and bearing from your present position.

To first step in creating a new waypoint (regardless of what method you're using) is to assign a name/identifier for the new waypoint.

To create a new waypoint from the user waypoint page:

1. Select the **'USR'** category from any waypoint category field and press **ENT**. The highlight will advance to the name field.
2. Enter the waypoint name.
3. Press **ENT** to accept.

REFERENCE

VORs & User Waypoints

WAYPOINT	
VOR: ABB	
NAME	
NAME IN	
112.40MHz DME	
N 38°35.327'	
W 085°38.161'	
GR LRS USA	
	000E3
126.77	119.00

VOR waypoint page

WAYPOINT	
USR: GARMIN	
N 30°01.494'	
W 097°46.940'	
20-JUN-96 15:35	
REF: -----	
BRG	DST
145°	3.21%
RENAME? NEW?	
DELETE? 000E3	
126.77	119.00

User waypoint page

Creating User Waypoints

WAYPOINT	
USR:	TOWER

REF:	-----
BRG	DST
-----	-----
RENAME? NEW?	-----
DELETE? DONE?	-----
130.75	119.00

Entering a new user waypoint's name.

WAYPOINT	
USR:	TOWER
N 35°29.186'	
W 107°20.600'	

REF:	-----
BRG	DST
145°	1.68m
RENAME? NEW?	-----
DELETE? DONE?	-----
130.75	119.00

Entering a new user waypoint's position.

Once the name has been accepted, the field highlight will move to the position field, where you can manually enter the position of the new waypoint:

1. Enter the lat/lon.

After the latitude and longitude entry is complete, press **ENT** to save the new waypoint. If you are defining the new waypoint position by referencing (entering a distance and bearing from) a known waypoint or your present position:

1. Highlight the 'REF' field.
2. If you are referencing a waypoint, enter the identifier of the reference waypoint (If you want to reference your present position, leave the 'REF' field blank.)
3. Press **ENT**. The field highlight will advance to the bearing field.

To enter a bearing and range from the reference position:

1. Enter the bearing of the new waypoint from the reference position.
2. Press **ENT** to confirm the bearing. The field highlight will move to the distance field.
3. Enter the distance of the new waypoint from the reference position.
4. Press **ENT** to confirm the distance. The GPSCOM 190 will calculate the coordinates of the waypoint and store it in memory.

User Comments

Once a new user waypoint is saved, the unit will assign a default user comment (the date and time of creation) to the new waypoint. You can replace the default comment to your own 16 character comment at any time, right from the user waypoint page.

To enter a user comment:

1. Highlight the comment field.
2. To clear the default comment, press the left arrow key when the cursor is in the left most character position.
3. Enter the comment and press **ENT**.

The delete and rename prompts, located near the bottom of the user waypoint page, allow you to quickly remove a waypoint from memory or change the name of an existing waypoint.

To delete a user waypoint:

1. Highlight 'DELETE?' and press **ENT**.
2. Highlight 'YES?' and press **ENT**.

The user waypoint page also allows you to rename any user waypoint in memory.

To rename a user waypoint:

1. Highlight 'RENAME?' and press **ENT**. The rename waypoint page will appear.
3. Enter the new waypoint name.
4. Press **ENT**. The highlight will advance to the 'Yes?' prompt.
5. Press **ENT** to accept the name, or **QUIT** to cancel.

Creating Waypoints with AutoStore

The **WPT** key is also used to save new waypoints using AutoStore. AutoStore allows you to quickly store your present position and add the new waypoint to a selected route if desired.

To save your present position using AutoStore:

1. Press **WPT** twice to capture your position (if you're already on a waypoint page, you'll only need to press the **WPT** key once).

The AutoStore page will appear, showing the captured position and a default 3-digit waypoint name. To change the default position name:

1. Highlight the name field and enter the name.
3. Press **ENT**. The highlight will move to the 'route' field.

If you'd like to add the waypoint to a route:

1. Press **ENT** and enter the desired route number using the arrow keypad and press **ENT** to confirm.

To save the AutoStore waypoint:

1. Highlight the 'SAVE?' field and press **ENT**.

REFERENCE

User Waypoints & AutoStore

WAYPOINT	
USR: 3R5	
N 30°07.214'	
W097°50.570'	

REF: KIXD	
BRG	DST
193°	00.00m
RENAME? NEW?	
DELETE? DONE?	
126.77	119.00

Entering a distance from a reference waypoint.

WAYPOINT	
USR: 3R5	
N 30°07.214'	
W097°50.570'	

REF: KIXD	
BRG	DST
193°	542m
RENAME? NEW?	
DELETE? DONE?	
126.77	119.00

Deleting a user waypoint.

Nearest Pages

NEAREST FSS
FACILITY SAN ANGELO
BRG DST 035° 12.1M
FREQUENCY 122.55
130.75 119.00

Nearest FSS Page

NEAREST CTR
FACILITY KANSAS CITY
BRG DST 254° 39.4M
FREQUENCIES 120.50 123.80
136.97 119.00

Nearest ARTCC Page

Nearest Pages

The **GO TO NEXT** key provides detailed information on the nine nearest airports, VORs, NDBs, INTs, and user waypoints to your present position, and is extremely useful for locating the nearest facility during an in-flight emergency. In addition, nearest flight services stations (FSS), Air Route Traffic Control Centers (ARTCC), and special use airspace alarms can also be viewed.

To view the nearest waypoints of a particular category (airports, VORs, NDBs, intersections or user waypoints), you need to select the desired category from the category field at the top of the nearest page. Let's practice by viewing the airports nearest to our present position:

1. Press **GO TO NEXT** twice to display the nearest page.
2. Press **ENT** to begin selection of the desired category.
3. Press the down arrow key repeatedly to scroll through the waypoint categories until 'APT' appears in the category field.
4. Press **ENT** to confirm the category. The field highlight will move to the first facility on the list.

Nearest Flight Service Station/ARTCC

The nearest function also gives you detailed information on the nearest FSS or ARTCC. The nearest FSS or ARTCC page displays the facility name, bearing and distance from your present position, and the facility's frequencies. To view the nearest FSS or ARTCC, you need to select 'FSS' or 'CTR' from the category field at the top of the nearest page. Let's practice by viewing the nearest FSS to our present position:

1. Press **GO TO NEXT** twice to display the nearest page.
2. Press **ENT** to begin selection of category.
3. Press the down arrow key repeatedly to scroll through the categories until 'FSS' appears in the category field.
4. Press **ENT** to confirm the category. The field highlight will move to the FSS frequency for selection as the standby frequency.

Frequency Entry/Com Pages

Transceiver Description

The GPSCOM 190 is a 760-channel digital VHF aviation communication transceiver with the following features :

- Transmits and receives on the VHF aviation communication frequency band which extends from 118.000 to 136.975 KHz, in 25 kHz steps.
- Receives ten weather frequencies, including all NOAA and most Canadian weather radio channels. The weather receiver has scanning capability plus severe weather alert tone detection.
- Receives the aviation VHF NAV (VOR/Localizer) band which extends from 108.000 to 117.950 MHz (audio only, no navigation capability).

Frequency Entry - Com Pages

You can quickly enter a frequency from a com page. The GPSCOM 190 will always display the active frequency at the top of every com page and the standby frequency below it.

To enter a frequency from any com page:

1. If you haven't done so yet, press **GPS COM** twice to enter the com pages while viewing the GPS pages.

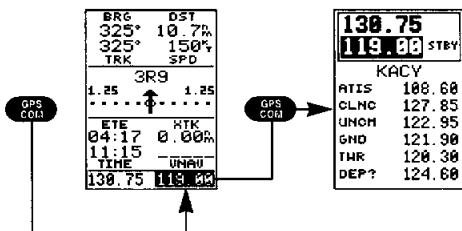

2. Enter the desired frequency in the highlighted standby frequency field. Note: you cannot directly enter a frequency into the active field.
3. Press **ENT** to confirm. Press the frequency transfer button to select the standby frequency as the active frequency.

To transmit on the active frequency:

1. Press the PTT switch.

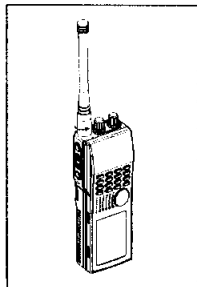

Transceiver specifications for the GPSCOM 190 are located in Appendix B.

IMPORTANT!

If the GPSCOM 190 is to be used in an aircraft, an aircraft radio license is required. If the unit is to be used as a ground station, then ground station authorization is required. See page ii for guidance on licensing requirements.

Com Function Page

Com Page Sequence

The GPSCOM 190 features three com pages in a continuous loop: com function, com frequency, and com menu. Try scrolling through the pages by pressing the **PAGE** key. You can also scroll in the opposite direction (or return to a previous page) by pressing **QUIT**.

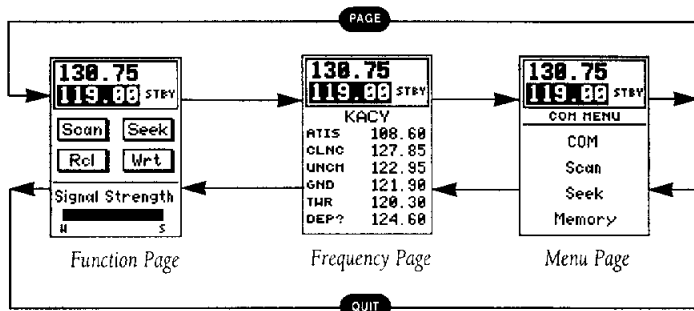

Press **PAGE** repeatedly until you access the com function page.

Com Function Page

The com function page controls scanning and seeking and memory writing and recalling. The com function page also displays a signal strength indicator in bar graph form that shows the relative strength of a received signal; W for weak, S for strong.

Scanning

How many times have you been on the ground near an airport and wanted to scan all the local frequencies? If you have used another handheld radio, you may have looked up the frequencies and entered them manually into memory channels, and scanned those. That process is a lot of work, especially if you want to turn around and do the same thing at another airport. The GPSCOM 190 allows you to scan all of the frequencies for the nine nearest airports (excluding ATIS) in the default scan mode (see scan mode setup submenu on page 39).

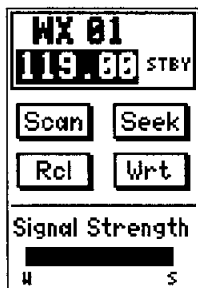

Com Function Page

Scanning and Seeking

When the GPSCOM 190 is scanning, it goes through the frequencies included in the scan, one by one, and stops on an active frequency. When scanning, the right side of the active frequency box displays 'SCAN'. When scanning stops (signal is detected), you will hear the transmitted audio and the word 'SCAN' is replaced with the letters 'RX'. Once the signal has gone inactive for two seconds (the default scan delay), the GPSCOM 190 will resume scanning until it detects another signal. See page 40 for instructions on how to change the scan delay.

To scan:

1. Highlight the graphic 'Scan' button and press **ENT**.

Scanning can be stopped in three ways:

- Break squelch by turning the squelch control counter-clockwise until audio is heard (scanning will resume once squelch is restored).
- Press the PTT switch or the frequency transfer button.
- Press **ENT** on the highlighted 'Scan' button. Once the unit has stopped scanning, you can press **ENT** and cycle the unit through each frequency in the scan list you have selected.

Seeking

The GPSCOM 190's seek mode is similar to scanning operation, without the delay function. When the unit is seeking, it goes through the selected frequencies, one by one, pausing on an active frequency. Once the receiver pauses on a frequency, it will remain stopped until you start seeking again. This allows you more "hands on" control. When the receiver pauses you will hear the transmitted audio and the word 'SEEK' will be replaced with 'RX'.

To seek:

1. Highlight the 'Seek' button and press **ENT**.

To stop seeking do any one of the following:

- Break squelch.
- Press the PTT switch or the frequency transfer button.
- Press **ENT** on the highlighted 'Seek' graphic button.

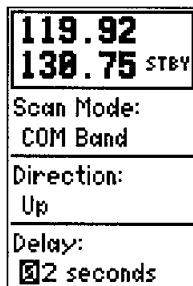

Entering a scan delay on the com function page.



The GPSCOM 190 in seek mode.

Memory/Com Frequency Page

130.75	
119.00 STBY	
Scan	Seek
Rcl	Wrt
Write 130.75 to channel 2	
QUIT?	SAVE?

Writing a frequency into memory.

130.75	
119.00 STBY	
Scan	Seek
Rcl	Wrt
01 118.00	
QUIT?	USE?

Recalling a frequency from memory.

Memory Write and Recall

Memory writing allows you to store your favorite com frequencies in memory.

To write a frequency into memory:

1. Highlight the 'WRT' box and press **ENT**.
2. Highlight the 'Write' field and enter the frequency.
3. Press **ENT**. The 'SAVE?' field is highlighted.
4. Press **ENT**.

You can recall a frequency from memory and place it in the standby frequency field.

To recall a frequency:

1. Highlight the 'Rcl' button and press **ENT**.
2. The highlight will move to the first occupied memory channel. Use the alphanumeric keys to enter the channel number you want to recall and press **ENT**.
3. Highlight 'USE?' and press **ENT**.
4. If no memory channels have been programmed, a message box will appear saying "No memory channels have been programmed". Press **ENT** to clear the box.

Com Frequency Page

126.77	
118.00 STBY	
50R	
UNCM	122.00
DEF	124.90
3R9	
APP	119.00
UNCM	123.00

The second com page is the com frequency page. The com frequency page provides a list of the airport frequencies at your departure (or nearest) and destination airports, allowing convenient selection of frequencies you'll need along your flight path. From the com page sequence, press **PAGE** until you see the com frequency page.

Frequency Information Page

From the com frequency page you can select a frequency and place it into the standby frequency field or into memory.

To select a frequency and place it in the standby frequency field:

1. Highlight the desired frequency and press **ENT**. The highlight will move to 'STANDBY?'. Press **ENT**.

The frequency you have selected is now placed in the standby frequency field.

To select a frequency and place it in memory:

1. Highlight the desired frequency and press **ENT**. Use the arrow keypad and highlight 'Memory?'. Press **ENT**.

The frequency you have selected is now entered into the next available memory channel.

Frequency Information Page

If a frequency has sector or altitude restrictions, the frequency type will be followed by a question mark.

130.75	
119.00 STBY	
KACY	
UNCH	122.95
GND	121.90
THR	120.30
DEP?	124.60
DEP?	134.25
CLS C?	124.60

To view the frequency information page:

1. Highlight the type field.
2. Press **ENT**. The display will show you the frequency information page, with bearing, altitude, and narrative restriction information.

130.75	
119.00 STBY	
KACY	
ATIS	108.60
CLNC	127.85
UNCH	STANDBY?
GND	MEMORY?
THR	120.30
DEP?	124.60

Selecting a frequency and placing it into the standby field.

FREQUENCY INFO	
BEARING	
003° - 170°	
ALTITUDE	
NONE	
NARRATIVE	
NONE	
126.77	119.00

Frequency Information Page

Com Menu Page



Com Menu Page

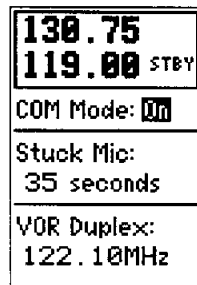

Com Setup Submenu

Com Menu Page

The com menu page allows you to customize communication setup. It displays the com menu list which allows you to select the com, scan, seek or memory setup pages.

To select a submenu from the com menu page:

1. Highlight the submenu you want to select.
2. Press **ENT** to display the submenu page.
3. To return to the com menu page, press **QUIT**.

Com Setup Submenu

From the com setup submenu you can select an operating mode, set 'Stuck Mic' timing, and setup for VOR duplex operation.

There are three modes of operation, 'On' (the default setting), 'Off', and 'Wx' (weather). Selecting 'Off' turns off the transceiver, allowing only GPS operation. Select 'Off' if battery life is a concern.

To turn the transceiver off:

1. Highlight the 'COM mode' field and press **ENT**.
2. Use the arrow keypad to select 'Off' and press **ENT**.

Weather Mode

Selecting 'Wx?' accesses the weather alert page where you can mute the receiver. Muting the receiver allows you to hear severe weather statements and warnings only, not the continuous normal broadcasts. In the mute mode, the receiver remains silent until the National Weather Service transmits a severe weather alert tone. Once the tone is received, the unit sounds a message beep and the center of the page displays the message 'Alert Tone Detected'. The unit automatically unmutes, enabling you to hear the severe weather statement, and will remain in this mode until the mute mode is reselected.

To mute the receiver:

1. Highlight the 'Audio' field and press **ENT**.
2. Press **ENT** to select 'Mute'.
3. Press **EXIT** to exit the weather alert page.

Com Menu Page Options

Stuck Microphone Timing

The stuck mic feature disables the transmitter after a selected length of time in the event of an open microphone or faulty transmitter.

To enter a stuck mic time:

1. Highlight the 'Stuck Mic' field.
2. Enter a time of up to 99 seconds and press **ENT**.

VOR Duplex Operation

There are times when voice features are used on a VOR frequency by ATC or FSS for transmitting instructions or information to pilots. The GPSCOM 190's VOR duplex feature allows you to transmit on a com frequency and receive on a VOR frequency.

To use VOR Duplex:

1. Enter the desired VOR receive frequency in the standby frequency field and push the frequency toggle button to make it the active frequency.
2. Highlight the VOR Duplex field and enter the desired com frequency.
3. Press the PTT switch. The VOR Duplex (com) frequency will become the transmit (active) frequency.
4. When the PTT switch is released, the unit will receive transmissions on the VOR frequency you entered in step one.

Scan Setup Submenu

The scan setup submenu allows you to customize the GPSCOM 190's scanning features. It displays scan mode, direction, and delay.

The scan mode field allows you to select a group of frequencies to scan: Nearest List, Memory, COM Band, and weather frequencies.

The GPSCOM 190 features four scanning modes:

- **Nearest List** scans the list of nearest airport frequencies.
- **Memory** scans all programmed memory channels.

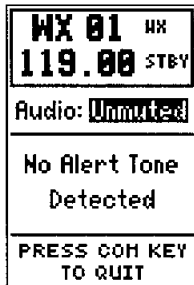

Audio mute option.

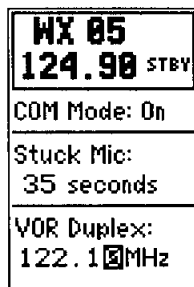

Changing a VOR duplex frequency.

Seek Setup Menu

130.75 119.00 STBY
Scan Mode: COM Band
Direction: Up
Delay: 2 seconds

Selecting a scan mode.

130.75 119.00 STBY
Seek Mode: COM Band
Direction: Up

Seek Setup Submenu

- **Com Band** scans the VHF Com Band from 118.00 to 136.975 MHz.
- **Wx Channels** scans all 10 weather channels.

To select a scan mode:

1. Highlight the 'Scan Mode' field and press **ENT**.
2. Use the arrow keypad to select a mode and press **ENT**.

The highlight moves to the 'Direction' field where you can select an ascending (up) or descending (down) scanning order.

To select a scanning direction:

1. Press **ENT** on the highlighted 'Direction' field.
2. Use the arrow keypad to choose a direction and press **ENT**.

The highlight moves to the 'Delay' field. After each transmission has ended, you may want to enter a delay-greater than the default setting of two seconds, ensuring that you'll hear both sides of a conversation before the unit starts scanning again. This delay is put on all channels.

To enter a time delay:

1. Enter a time up to 99 seconds and press **ENT**.

Seek Setup Submenu

The seek setup submenu allows you to customize the GPSCOM 190's seek features. Unlike scanning, seeking gives you more "hands on" control. Seeking lets you proceed at your own pace letting you stay on a stopped frequency as long as you like. This will allow you to continue to hear a conversation containing pauses. Once the receiver stops on a seek frequency, it will remain stopped until you break squelch, press PTT or the frequency transfer button.

To select a seek mode and direction:

1. Highlight the 'Seek Mode' field and press **ENT**.
2. Choose a mode and press **ENT**. The highlight moves to the direction field where you can press **ENT**, choose a direction and press **ENT** again.

Memory Setup Submenu

The memory setup submenu lets you manage the memory features of the GPSCOM 190 including locking out frequencies. Any frequency locked out will be skipped over during scanning. For example, if you are scanning all the frequencies in memory for a particular airport which has ATIS, the scan will stop on ATIS and never resume scanning, because the ATIS transmission is continuous. Locking ATIS out will prevent the constant stopping.

To enter a frequency into an empty memory channel:

1. Highlight the memory channel frequency field.
2. Enter the desired frequency and press **ENT** to confirm. The highlight will move the lock icon where you can lock the frequency by pressing **ENT**.
3. Unlock the frequency by pressing **ENT** again.

Memory Comments

Each channel may be given a 15 character user comment.

To enter comments:

1. Highlight the comments field.
2. Enter up to 15 characters and press **ENT**. The highlight moves to the next memory position.

Memory Changes

There may be times you'll want to change or insert an existing frequency and its corresponding comments in memory.

To change a frequency in memory:

1. Highlight the frequency field and press **ENT**.
2. Use the arrow keypad to select 'CHANGE?'
3. Enter the new frequency
4. Press **ENT** to confirm.

To change comments in memory:

1. Highlight the comments field.
2. Enter the new comments and press **ENT**.

WX 05	
124.90	STBY
1	121.50

2	_____

3	_____

Entering a frequency into memory.

WX 01	
119.00	STBY
1	118.00
2	_____

3	_____

Entering frequency comments.

Emergency Frequency Selection

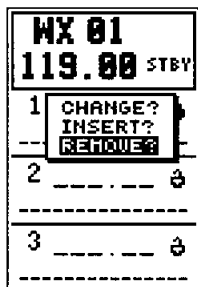

Removing a frequency from memory.

Memory Changes (cont.)

To insert a frequency into memory:

1. Highlight the frequency field and press **ENT**.
2. Use the arrow keypad to select 'INSERT?'
3. Enter the new frequency.
4. Press **ENT** to confirm.

To remove a frequency in memory:

1. Highlight the frequency you wish to remove and press **ENT**.
2. Select 'REMOVE?'
3. Press **ENT**.

Emergency Channel Selection

1. Press and hold **GPS CO1**.



The GPSCOM 190's emergency channel selection feature provides a quick method of selecting the 121.5 MHz frequency as the active frequency in the event of an in-flight emergency. The feature is available whenever the unit is on, regardless of GPS or communication status, or in the unlikely loss of the of display.

To select the 121.5 MHZ frequency as the active frequency:

1. Press and hold **GPS CO1**.

To transmit on the emergency frequency:

1. Press the PTT switch.

Going To a Destination

One of the many benefits of GPS navigation is the ability to fly directly to a waypoint or fly along a chain of waypoints without relying totally on ground-based navigation aids. To take advantage of the convenience and efficiency of point-to-point GPS navigation, the GPSCOM 190 provides three methods of selecting a destination for your flight: GOTO, TracBack and route navigation.

The GOTO function provides a fast way to set a course to a destination from your present position, while the route function allows you to create a chain of waypoints to follow in sequence toward a selected destination.

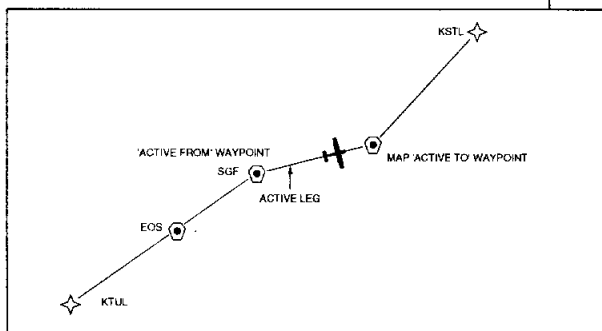

Whether you're flying a GOTO course or a route, there are a few basic concepts and terms that apply to all point-to-point GPS navigation. Routes are broken down and navigated in smaller segments called "legs". The diagram above shows a basic route consisting of five waypoints and four legs.

The waypoint you are going to in a leg is called the "active to" waypoint (MAP), and the waypoint immediately behind you is called the "active from" waypoint (SGF). The line between the "active to" and the "active from" waypoint is called the "active leg". When you activate a route with the GPSCOM 190, it will automatically select the route leg closest to your position as the active leg, and provide navigation guidance directly to the "active to" waypoint of that leg.

GOTO Key**GO TO:**

- PRESS ENTER TO
ACTIVATE
NAVIGATION

- PRESS GOTO TO
SEE NEAREST
WAYPOINTS/SUA

126.77 119.00

To cancel GOTO navigation, use the LEFT ARROW key to clear the identifier field, and press ENTER.

NEAREST UOR



WAYPT	BRG	DIS
LOA	044'	116
IAH	082'	122
ACN	355'	153
3R9	018'	170
HQP	349'	172
FZT	034'	173
TQA	316'	179
DFH	005'	183
ABI	319'	192
121.50		124.90

You may access the nearest waypoints page from the GOTO page by pressing the GOTO key twice.

GOTO Function

The GPSCOM 190's GOTO function lets you choose any stored waypoint as a destination and quickly set a course from your present position. Once a GOTO has been activated, the navigation page will provide you with steering guidance to your destination.

To activate the GOTO function:

1. Press .
2. The GOTO page will appear with the waypoint field ready to select a destination. Enter identifier destination waypoint.
3. Press  to confirm the waypoint.

Waypoint Name
Field

GO TO:

- PRESS ENTER TO
ACTIVATE
NAVIGATION

- PRESS GOTO TO
SEE NEAREST
WAYPOINTS/SUA



126.77 119.00

GOTO Options

You can also quickly activate the GOTO function from any other page by simply highlighting an identifier, pressing the  key and confirming the GOTO page. This method can be used to re-center the CDI on the destination waypoint, or to fly a route out of sequence.

Once a GOTO is activated, the GPSCOM 190 will provide navigation guidance to the selected waypoint until the GOTO is cancelled.

To cancel an active GOTO:

1. Press .
2. Use the left arrow key to clear the field.
3. Press  to complete the cancellation.

TracBack Navigation

TracBack Navigation

Another method of navigating to a destination is by using the TracBack function. TracBack allows you to quickly and easily retrace your path using the track log automatically stored in the receiver's memory. The advantage of TracBack is to eliminate the need to mark waypoints along the way and manually create and activate a route back to where you began your trip.

The TracBack route is created by reducing your current track log into a route of up to 30 waypoints, and activating an inverted route along those points. Once activated, a TracBack route will lead you back to the oldest track log point stored in memory, so it's usually a good idea to clear the existing track log at the start of your current trip before you take off.

To clear the track log and define a starting point for a TracBack route:

1. From the setup menu or map configuration page, highlight the 'TRACK LOG' option. Press **ENT** to access the track log page.
2. Use the up arrow key to highlight the 'CLEAR TRACK LOG?' option.
3. Press **ENT**. The clear log confirmation page will appear. Use the left arrow key to highlight the 'Yes?' prompt and press **ENT**.

To activate a TracBack route:

1. From the the setup menu or map configuration page, highlight the 'TRACK LOG' option. Press **ENT** to access the track log page.
2. Highlight the 'TRACBACK?' option and press **ENT**.

Once TracBack has been activated, the unit will take the track log currently stored in memory and divide it into segments called "legs". Up to 30 temporary waypoints (e.g., 'T001') will be created to mark the most significant features of the track log in order to duplicate your exact path as closely as possible. A TracBack route from your present position to the oldest track log point will be created as the active route (the active route page will appear), and provide steering guidance to each waypoint back to the starting point of your track log.

TRACK LOG
RECORD TRACK: Yes
CRITERIA: Automatic
MEMORY USED 1% 37 OF 2048 PMTS
TRACBACK?
CLEAR TRACK LOG?
126.77 119.00

To define the starting point for TracBack navigation, clear the track log at the beginning of each trip.

TRACK LOG
RECORD TRACK: Yes
CRITERIA: Automatic
MEMORY USED 1% 38 OF 2048 PMTS
TRACBACK?
CLEAR TRACK LOG?
126.77 119.00

To begin navigation of a TracBack route, highlight the 'TRACBACK?' prompt and press ENTER.

TracBack Navigation

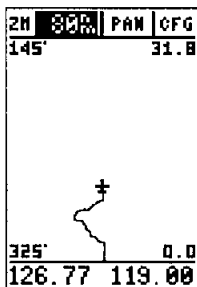

The TracBack function allows you to navigate your track log back to the oldest track point in memory.

ACTIVE ROUTE		
TRACBACK		
WAYPT	DTH	DIS
T003	---	---
T002	---	---
T001	007'	562
---	---	---
---	---	---
---	---	---
---	---	---
CLEAR? INVERT?		
126.77	119.00	

To save a TracBack route, be sure to copy route 0 to another route. To save a temporary waypoint, simply rename it following the instructions on page 31.

Tips on Creating and Using the TracBack Feature

The GPSCOM 190's TracBack feature is designed to help you quickly create and activate a route that follows your path back to a user-defined starting point. To get the most out of the TracBack feature, remember the following tips:

- Always clear your track log at the exact point which you will want to go back to (airport, landing field, etc.).
- The 'RECORD' option on the track log setup page must be set to the 'Yes' position.
- There must be at least two track log points stored in memory to create a TracBack route.
- If there are not enough available waypoints in memory to create a TracBack route, you will be alerted with a 'waypoint memory full' message. The receiver will use any available waypoints to create a TracBack route with an emphasis on the track log closest to the destination (the oldest track log point in memory).
- If the 'CRITERIA' option on the track log setup page is set to a time interval, the TracBack route may not follow your exact path (keeping the criteria set to automatic will always provide the best TracBack route).
- If the changes in direction and distance of your track log are very complex, 30 waypoints may not be enough to accurately mark your exact path. The receiver will then assign the 30 waypoints to the most significant points of your track and simplify segments with fewer changes in direction.
- If you want to save a TracBack route, copy route 0 to an open storage route before activating another TracBack. Activating another TracBack or storage route will overwrite the existing TracBack route.
- Whenever a TracBack route is activated, the receiver will automatically erase any temporary waypoints (e.g., 'T001') that are not contained in routes 1-19. If there are temporary waypoints stored in routes 1-19, the receiver will create any new temporary waypoints using the first three-digit number available.

Route Pages

Route Definition Page

The GPSCOM 190 lets you create and store up to 20 routes of 30 waypoints each. Routes are created, copied and edited through the route definition page, which is accessed through the main menu page.

To select the route definition page:

1. Press **PAGE** until the main menu page appears.
2. Use the arrow keypad to highlight the 'Routes' option.
3. Press **ENT** to display the routes page.
4. To return to the main menu page, press **QUIT**.

	ROUTE: 1	Route Number
Route Comment Field	NOJC TO MNKC	
	NO WAYPNT DTH DIS	Distance to Waypoint
Route Waypoints	1. NOJC 275 44	Bearing to Waypoint
	2. MNKC 073 51	
	3. MNKC 215 22	
	4. MNKC 215 22	
	5. -----	
	TOTAL DST 117	Total Route Distance
Route Function Fields	COPY TO:	
	CLR? INV? ACT	
	126.77 119.00	'COPY TO' field

The route number field is displayed at the top of the page, with a 16-character comment field below. If no user comment is entered, the field will display the first and last waypoint in the route. The waypoint list accepts up to 30 waypoints for each route, with fields for desired track and distance between legs. (If the leg distance exceeds 999 nm, the field will remain blank.)

Below the waypoint list are the route page function fields which let you copy, clear, invert or activate the displayed route. Routes 1-19 are used as storage routes, with route 0 always serving as the active route you are navigating. If you want to save a route currently in route 0, be sure to copy it to another open route, as it will be overwritten by the next route activation.

AUTOSTORE
Waypoint:
001
N 30°07.063'
W 097°50.483'
Add to route
number: 1
SAVE?
126.77 119.00

A route may also be created using the GPSCOM 190's AutoStore function. Simply enter a route number in the route field before saving the waypoint.

Note: If you enter the number of an existing route, the waypoint you are adding will be added to the end of that route. It will not be geographically placed between the beginning and end of the route.

Creating & Copying Routes

ROUTE: 1			
KOJC TO KHRG			
NO	WAYPNT	DTR	DIS
1.	KOJC	275'	44
2.	KFOE	073'	51
3.	KHRG	---	---
4.	KHXD	---	---
5.	---	---	---
TOTAL DST		95.0	
COPY TO: --			
CLR? INU? ACT?			
126.77		119.00	

You can construct a route manually by entering the names of individual waypoints in any order you choose.

ROUTE: 1			
KOJC TO KHRG			
NO	WAYPNT	DTR	DIS
1.	KOJC	275'	44
2.	KFOE	073'	51
3.	KHRG	215'	22
4.	KHXD	---	---
5.	---	---	---
TOTAL DST		117	
COPY TO: 1?			
CLR? INU? ACT?			
126.77		119.00	

To copy a route, simply highlight the 'COPY TO:' field, press ENTER, and enter the route number.

Creating a Route

The route definition page is used to create up to 20 routes of 30 waypoints each.

To create a route:

1. Highlight the route number field at the top of the page and press **ENT**.
2. Select the desired route number and press **ENT**.
3. Press **ENT** to confirm the route number.
4. Enter your comment and press **ENT**.
5. Enter the name of the first route waypoint and press **ENT**.
6. Continue entering the rest of your waypoints in order. You may enter up to 30 waypoints.
7. After you have finished entering all your waypoints, press **PAGE** to return to the menu page.

Copying and Clearing Routes

The route definition page is also used to copy a route to another route number. This feature is useful when you make changes to the active route (route 0) and want to save both the new route and the original route.

To copy a route:

1. Highlight the route number field at the top of the page and press **ENT**.
2. Select the desired route number and press **ENT**.
3. Move the field highlight to the 'COPY TO' field and press **ENT**.
4. Use the arrow keypad to scroll through the available routes and select a destination route number. Only open routes will be available as choices.
5. Press **ENT** to copy the route.
6. Press **PAGE** to return to the menu page.

Clearing & Activating Routes

Clearing a Route

The route action fields, located near the bottom of the route definition page, allow you to clear, invert and activate the routes stored in the GPSCOM 190.

To clear a route:

1. Highlight the route number field at the top of the page and press **ENT**.
2. Select the desired route number and press **ENT**.

A warning page will appear, asking you to confirm that you want to remove all waypoints from the route.

3. Highlight the 'Yes' field with the left arrow key and press **ENT**.
4. Press **PAGE** to return to the menu page.

Activating or Inverting a Route

After a route has been entered in the GPSCOM 190, it can be activated in its sequence or inverted (in reverse order). The process of activating or inverting a stored route takes a storage route (routes 1-19) and copies it into the active route (route 0) for navigation.

This system allows you to have an active route that you may edit during navigation and save as an entirely new route from the original. You will have to copy the active route to an unused storage route to save it, since new route or TracBack activation overwrites route 0.

To activate a route:

1. Select the route definition page and press **ENT** to activate the route number field.
2. Select the route number to be activated and press **ENT**.
3. Highlight the 'ACT?' field and press **ENT**.

Inverting a route allows you to navigate route legs in reverse order without editing the original route.

To activate a route in inverted order:

1. Follow the same steps as above, but select the "INV?" field and press **ENT**.

CLEAR ROUTE	
WARNING!	
all waypoints will be removed from this route	
Are you sure Yes? or No?	
WX 05	124.90

To clear a route, highlight the 'Yes?' prompt and press ENTER

ROUTE: 1			
NOJC TO KHRG			
NO	WAYPNT	DTR	DIS
1.	KOJC	275'	44
2.	KFOE	073'	51
3.	KHRG	215'	22
4.	KIXD	---	---
5.	---	---	---
TOTAL DST			117
COPY TO: ---			
CLR? INV? ACT?			
126.77	119.00		

To activate a route, highlight the 'ACT?' prompt and press ENTER.

Active Route Page

ACTIVE ROUTE		
KOJC TO KMKC		
WAYPNT	ETE	DIS
KOJC	--:--	----
KFOE	--:--	----
KMKC	03:59	539
KIXD	04:09	561
----	--:--	----
----	--:--	----
----	--:--	----
CLEAR? INVERT?		
126.77	119.00	

Active Route Page

Use the active route page to keep track of the estimated time enroute and distance to upcoming waypoints.

ACTIVE ROUTE		
KOJC TO KMKC		
WAYPNT	ETA	DIS
KOJC	--:--	----
KFOE	--:--	----
KMKC	19:32	537
KIXD	19:41	560
----	--:--	----
----	--:--	----
----	--:--	----
CLEAR? INVERT?		
126.77	119.00	

The active route page can be configured to display the ETA for each route waypoint.

Active Route Page

Once a route has been activated, the active route page will appear, displaying the waypoint sequence of your route with the estimated time enroute (ETE) at your present speed and distance to each waypoint. As long as you are navigating an active route, the active route page will become part of the main page sequence of the unit.

The active route page will also allow you to change the ETE field to display desired track (DTK) or estimated time of arrival (ETA) for each leg. You can also clear or invert the active route.

To display DTK or ETA for each leg:

1. Highlight the 'ETE' field and press **ENT**.
2. Use the up or down arrow keys to select 'DTK' or 'ETA' and press **ENT**.

To invert a route from the active route page:

1. Press the up arrow key once to move the field highlight to the 'INVERT?' field.
2. Press **ENT** to invert the route.

To clear the active route from the active route page and stop route navigation:

1. Use the up and left arrow keys to select the 'CLEAR?' field.
2. Press **ENT**. Highlight the 'Yes?' prompt on the warning page and press **ENT** to complete.

Once a route has been created and stored in the GPSCOM 190, it can be edited at any time—even as an active route.

To edit a route from the active route page or the route submenu page:

1. Use the up and down arrow keys to select the waypoint to edit and press **ENT**.

An on-screen menu of editing choices will appear, with options for reviewing, inserting, deleting or changing the waypoint field highlighted. Use the up and down arrow keys to select from the editing choices.

Editing Routes

Reviewing & Editing Routes

Once you've selected a waypoint from the route list, choose a menu function:

1. To review the definition page for the waypoint, highlight the 'review?' field and press **ENT**.
2. To add a new waypoint that precedes the selected waypoint, highlight the 'insert?' field and press **ENT**.
3. To remove the selected waypoint, highlight the 'remove?' field and press **ENT**.
4. To replace the selected waypoint with a new waypoint, highlight the 'change?' field and press **ENT**.

To complete your changes, use the waypoint editing instructions described earlier (see page 24) for creating a route. If you're editing the active route (route 0), copy the new route version to an empty route to save it. Otherwise, it will be overwritten by a new route activation.

If you add, delete or change the first or last waypoint of a route, the default comment (first and last waypoint) will automatically be updated after you make the changes.

On-Route GOTOs

At the beginning of the route section, we mentioned that the GPSCOM 190 will automatically select the route leg closest to your position as the active leg. This will give you steering guidance to the "active to" waypoint of that leg, based on the desired track of the active leg. If you would prefer to navigate directly toward the "active from" waypoint, you can perform an "on-route GOTO" right from the active route page.

To perform an on-route GOTO:

1. Use the up and down arrow keys to highlight the desired route waypoint and press **GOTO FIRST**.
2. Once the GOTO page appears, press **ENT** to confirm the on-route GOTO waypoint.

Once you reach the GOTO waypoint, the GPSCOM 190 will resume navigating the rest of the active route in sequence.

ACTIVE ROUTE		
KOJC TO MNKC		
WAYPNT	ETA	DIS
KOJC	---	---
KFOE		
MNKC		
KIXD		

CLEAR? INVERT?		
126.77	119.00	

Select a route edit option from the pop-up window.

ROUTE: 1			
KOJC TO MNKC			
NO	WAYPNT	DTK	DIS
1.	KOJC	275'	44
2.	KFOE	073'	51
3.	MNKC	215'	22
4.	KIXD	---	---
5.	---	---	---
TOTAL DST			117
COPY TO: --			
CLR? INU? ACT?			
WX 05	124.90		

To fly the active route out of sequence, simply highlight the waypoint you want to navigate to and press GOTO.

Satellite Status Page

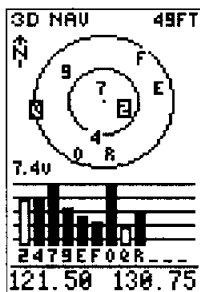

Satellites in view but not currently in use (Q & 2) will be highlighted with a black rectangle, and will show a corresponding "hollow" signal strength bar.

IMPORTANT!

The satellite status page displays current battery voltage. Any voltage above 7.2 volts shows a fully charged condition. You should charge the Ni-Cad battery pack when the voltage drops below 7.2. At 5.8 volts, you will get a low battery voltage message. At 5.5 volts, the Com and GPS functions shutoff. It is normal to see a drop in voltage when transmitting.

Satellite Status Page

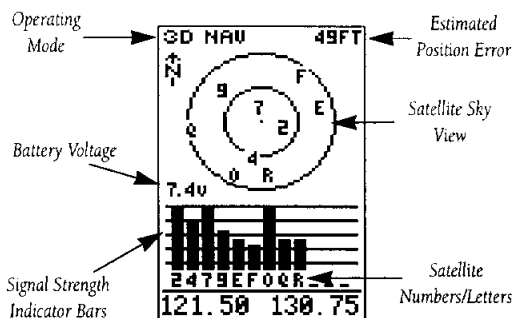

The satellite status page displays the status of various receiver functions. This status information helps you understand what the GPS is doing at any given time, and tells you whether or not the receiver has calculated a position fix.

The sky view and signal strength bars give you an indication of what satellites are visible to the receiver, whether or not they are being used to calculate a position fix, and the signal strength.

The sky view in the center of the page shows a bird's-eye view of the position of each satellite relative to the receiver's last known position. The outer circle represents the horizon (north up); the inner circle is 45° above the horizon; and the center point is a position directly overhead.

When the receiver is looking for a particular satellite, the corresponding signal strength bar will be blank and the sky view indicator will be displayed as white letters/numbers in a black box. Once the receiver has found the satellite, a hollow signal strength bar will appear and indicate that the satellite has been found and the receiver is collecting data from it.

The satellite number or letter in the sky view will also change from reverse video to black numbers/letters with no box surrounding them. As soon as the GPSCOM 190 has collected the necessary data to use the satellite for positioning, the hollow bar will become solid.

Satellite Status Page

Receiver Status

Receiver status is displayed at the top left of the screen, with the current horizontal accuracy (estimated position error, in feet or meters) at the top right. The status field will show one of the following conditions:

Searching— the receiver is looking for any available satellites in view.

AutoLocate— the receiver is initializing and collecting new almanac data. This may take 3 to 5 minutes.

Acquiring— the receiver is collecting data from available satellites but has not collected enough data to calculate a 2D fix.

2D Navigation— at least three satellites with good geometry have been locked onto, and a 2-dimensional position fix (latitude and longitude) is being calculated. '2D Diff' will appear when you are receiving DGPS corrections in 2D mode.

3D Navigation— at least four satellites with good geometry have been locked onto and your position is now being calculated in latitude, longitude and altitude. '3D Diff' will appear when you are receiving DGPS corrections in 3D mode.

Poor GPS Coverage— the receiver is no longer tracking enough satellites for a 2D or 3D fix.

Not Usable— the receiver is unusable, possibly due to incorrect initialization or abnormal satellite conditions. Turn the unit off and back on to reset.

Simulating Navigation— the receiver is in simulator mode.

EZinit Prompt

The satellite status page also displays the EZinit prompt whenever a position fix has not been calculated (the unit must be in searching, AutoLocate, acquiring, or poor coverage mode).

This prompt allows you to manually reinitialize. Its a useful feature if you have traveled over 500 miles with the receiver off and you know it must be initialized to your new position (the unit will also automatically offer the EZinit prompt after 3-5 minutes of unsuccessful satellite acquisition).

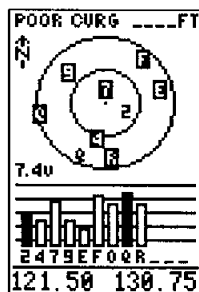

A poor coverage status will appear if the receiver has lost the number of satellites required to compute a fix.

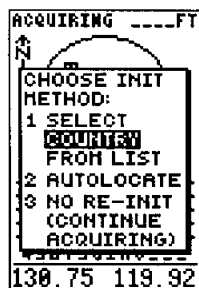

The EZinit prompt will automatically appear if the receiver needs to be initialized. The prompt may also appear during normal use if the antenna is shaded or the unit is indoors.

Position Page

030 345 N 015 0	
TRACK	SPEED
356°	130%
TRIP	ALT
161.7M	2500F
N 39°02.524'	
W095°00.000'	
17:27:08	
119.92	130.75

Entering an altitude manually.

N 015 030 NE	
TRACK	SPEED
024°	150%
TRIP	ALT
000.0M	2501F
N 30°45.570'	
W098°03.415'	
15:55:53	
126.77	119.00

The trip odometer may be reset to measure your distance traveled.

Position Page

The position page displays your current position's latitude, longitude, altitude and time numerically. It displays your track (compass direction) and speed whenever you're moving.

The position page lets you enter a position's latitude and longitude manually. During satellite acquisition, the position displayed is the last computed position stored in memory. To speed up the acquisition process, you can enter a more accurate initial position or reference airport (see page 63). Be sure to accurately enter the latitude and longitude to the nearest degree.

To manually enter a position:

1. Highlight the position field.
2. Use the alphanumeric keys to enter the new position.
3. Press **ENT** to confirm.

When the GPSCOM 190 is acquiring satellites or navigating in the 2D mode, the last known altitude will be used to compute your position. You may also manually enter an altitude. Keep in mind that GPS altitude may vary significantly from pressure altimeters. Never use GPS altitude for vertical navigation.

To enter an altitude manually:

1. Highlight the altitude field.
2. Use the alphanumeric keys to enter the altitude.
3. Press **ENT** to confirm the altitude.

The position page also features a resettable trip odometer to measure the total distance traveled while navigating.

To reset the trip odometer:

1. Highlight the trip field.
2. Press the left arrow key while the highlight is on the left most character position.

Map Page

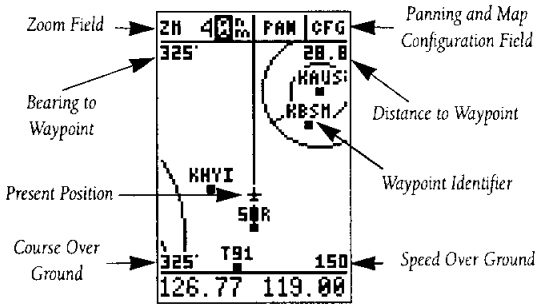

The map page plots your course and route on a moving map. It also provides you with a cursor that will let you pan ahead and review nearby waypoints, determine the distance and bearing to map position and mark new waypoints. The map page can be broken down into three sections:

The **zoom, panning control and map configuration fields** are all located at the top of the screen. There are 12 selectable zoom ranges from 0.2 to 320 miles or 0.5 to 600 km, measured vertically. The pan field provides access to the map cursor, while the configuration field allows you to specify what items are displayed and when they appear.

The **map portion** of the page shows your movement over ground. Your present position is indicated by a plane icon (in track up mode), or a position diamond (in other modes), with your track and/or route displayed as a solid line. Nearby waypoints are represented as squares, with the waypoint name also listed. Through the map configuration page, you may select which features are displayed (see page 58 for more information).

The **data fields** located at the four corners of the map, show the bearing and distance to a destination waypoint and your current track and speed over ground. The two fields at the top corners of the map show your bearing and distance to one of three selectable destinations: an active destination waypoint, a highlighted on-screen waypoint, or the target crosshair. If you are not navigating to a waypoint or using the panning function, the top data fields will not be displayed.

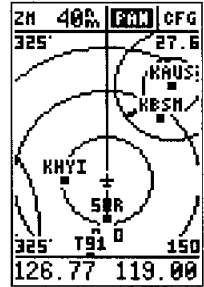

The GPSCOM 190 has on-screen range rings to help you estimate distances relative to your present position. The value of each ring is determined by the current zoom scale. Range rings may be turned on or off through the map configuration menu.

Basic Zooming & Panning

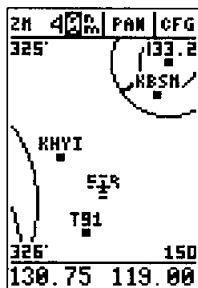

The GPSCOM 190 offers 12 zoom scales from 0.2 to 320 nm.

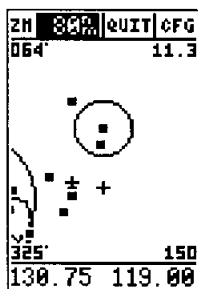

Use the panning mode to view the area surrounding your current position and nearby waypoints.

Map Page Functions

There are four main functions you can perform from the map page— zooming, pointing, panning and map configuration. Each of these functions has its own “field”, which may be selected and activated for use.

Whenever the map page first appears, the zoom field (at the top left) is always selected. The map page has 12 map scales which are selected through the zoom field.

To select a zoom scale:

1. Press the left or right arrow keys to highlight the zoom field.
2. Press **ENT** to begin range selection.
3. Use the up or down arrow keys to scroll through and find the desired range scale. Press **ENT** to confirm your selection.

The second function field on the map page is the pan field. The pan function allows you to move the map with the four arrow keys to view areas outside the current map.

To activate the pan function:

1. From the zoom field, use the right arrow key to highlight the pan field and press **ENT**.
2. Use the arrow keys to move the map in any direction.

As you begin to move the map, a crosshair will appear. This crosshair will serve as a target marker for the moving map. The distance and bearing to destination (at the top of the page) will now be replaced by the distance and bearing from your present position to the target crosshair.

As you pan around the moving map display, you'll notice that the target crosshair will “snap” to on-screen waypoints and highlight the waypoint name. Once a waypoint name is highlighted, you can review its waypoint definition page or execute a GOTO function by using the ENTER or GOTO/NRST key.

To stop the panning function and return to your present position:

1. Press **QUIT**.

Advanced Zooming & Panning

Selecting Waypoints on Screen

From the zoom or pan fields, the cursor highlight may be moved into the map display by pressing the down key. The arrow keys will now move the highlight through the map and “point” at on-screen waypoints.

To point at a displayed waypoint:

1. Use the arrow keys to move the cursor highlight from the zoom field into the map field.
2. Once you are in the map field, use the four arrow keys to scroll through on-screen waypoints. The arrow key you use will determine the direction of your scroll.
3. When you have scrolled through all the on-screen waypoints, the cursor will move back to the zoom or pan function field.
4. To return the field highlight to the zoom field, press

QUIT

Once a waypoint has been selected in the map field, its distance and bearing from your present position will be displayed in the destination field.

Advanced Zooming & Panning

To get the most out of panning, you need to be able to zoom in and out while you're panning. This lets you move the map at a faster speed and zoom in for waypoint details. Once the pan function is activated, the cursor highlight moves back to the zoom field.

To adjust the zoom range while panning:

1. Press the **ENT** key to begin zoom scale selection.
2. Use the up and down arrow keys to select the map scale. Press **ENT** to return to normal panning mode.

During panning, the crosshair represents a target position on the map, with the range and bearing to the target displayed at the top of the screen. You can also use the target crosshair to mark a new waypoint position or as a GOTO destination right from the map field.

To mark the crosshair position as a new waypoint:

1. Press **WPT** to capture the position.
2. Enter a new name and route number if you wish and press **ENT** to return to the map page.

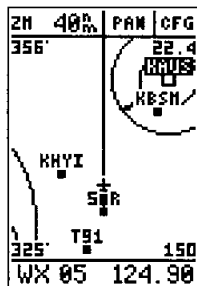

To highlight an on-screen waypoint, simply place the cursor on top of the waypoint. A black box will appear around the waypoint with the name shown in white letters.



While panning, you may change the zoom scale without having to switch from the panning mode.

Map Waypoints

GO TO:

MAP ___

- PRESS ENTER TO ACTIVATE NAVIGATION
- PRESS GOTO TO SEE NEAREST WAYPOINTS/SUA

126.77 119.00

Be sure to rename the "MAP" waypoint if you want to save it, as it will be overwritten when you perform your next GOTO.

MAP CONFIG

WAYPOINTS?
 AIRSPACE?
 ROUTE: ON
 AUTO ZOOM: ON
 RINGS OFF
 TRK LOG: 250
 ORNTN: TRK UP

TRACK LOG?

WX 05 124.90

Map Configuration Page

You may custom tailor the map to your needs by selecting from a variety of changeable options which are controlled from the map configuration page.

You can also use the target crosshair as an instant GOTO destination. This function will AutoStore the position and set a course for a new waypoint called 'MAP'.

To GOTO the target crosshair:

1. Press **GOTO** **FAST** to capture the position.
2. Press **ENT** to confirm the MAP GOTO.
3. Press **QUIT** to return to the map page.

In saving the MAP waypoint, be sure to rename it, as it will be overwritten the next time a map GOTO is executed.

Map Configuration

The last function you can perform from the map page is map configuration, which lets you select what features are displayed on the map, set the map orientation and manage the track log functions.

To access the map configuration function:

1. Highlight the 'CFG' field on the map page and press **ENT**.

The map configuration page will appear, listing the following options: waypoint viewing scale, airspace viewing scale, routes and plot point options, AutoZoom, orientation, rings, and track log.

Waypoint Category Viewing Scale

The waypoints field provides access to the map waypoint setup page, which allows you to define what waypoint types are displayed on the map and the scales in which they will appear. The categories on the setup page are: APT, INT, NDB, VOR, User and Wpt identifier. These let you designate a minimum map scale or allow you to turn the category off altogether. Each category has 13 adjustable settings, from 0.2 nm to 320 nm and off.

To change the waypoint category viewing scale:

1. Highlight the desired category viewing scale and press **ENT**.
2. Use the up and down arrow keys to select the desired setting, and press **ENT**.

Map Configuration

Map Airspace Options

The next listing on the map configuration page is 'AIRSPACE' which provides access to the map airspace setup page. The map airspace setup page allows you to designate a minimum map scale or allows you to turn off a selected airspace category. Each category has 13 adjustable settings, from 0.2 nm to 320 nm and off. The 'OTHER SUA' airspace category includes alert, caution, danger, warning, and training areas. The 'OTHER CTRL' category includes control zone warnings (Europe) and control tower warnings which display an alarm message when an aircraft is within five nautical miles around an airport with a control tower and 2,500 feet above airport elevation. Prohibited airspaces are not selectable, and are always displayed. Turning off an airspace simply removes it from the map display and **DOES NOT** turn off the alert messages for an airspace category. For more on SUAs, see page 73.

To change the airspace category viewing scale:

1. Highlight the desired category viewing scale and press **ENT**. Use the up and down arrow keys to select the desired setting, and press **ENT**.

Routes

The next listing on the map configuration page is 'ROUTE', which allows the user to select whether or not the GPSCOM 190 will display the straight-leg lines between the waypoints of an active route and display all route waypoint names.

To change the routes setting:

1. Highlight 'ROUTE' and press **ENT**. Use the up and down arrow keys to select the desired setting, and press **ENT**.

AutoZoom, Range Rings, and Track Log

The map configuration page lets you turn AutoZoom (see page 60) and range ring features on or off and define a map orientation. The "ORNTN" field lets you set the map to a north up, track up (the direction of current travel) or a desired track up (the direction of an active route leg) orientation. The "TRK LOG" field sets the number of points the unit will attempt to plot.

MAP AIRSPACE	
Cls B/CTA:	320%
Cls C/TMA:	320%
Othr Ctrl:	20%
MOA:	320%
Restrict:	320%
Othr SUA:	320%
121.50	124.90

The map airspace setup page allows you to designate a minimum map scale or allows you to turn off a selected airspace category.

TRACK LOG	
RECORD TRACK:	Yes
CRITERIA:	Automatic
MEMORY USED	0%
	9 OF 2048 PNTS
TRACKBACK?	
CLEAR TRACK LOG?	
126.77	119.00

The track log page is available from the map configuration and main menu pages.

Map Configuration

At the bottom of the map configuration page is the track log submenu which controls all the track log features (see page 67). The track log can be set up through the map configuration page or through the track log submenu on the main menu page.

To set AutoZoom, range rings, or map orientation:

1. Highlight the desired map display field setting and press **ENT**.
2. Use the up and down arrow keys to select the desired setting, and press **ENT**.

The plot points function sets the number of points the unit will attempt to plot. The maximum number of points that can be displayed is 2048 if all 2048 points are selected. Note: Once you've reached the maximum number of plot points allowed in memory, the older points will be lost as new ones are added.

To set the number of plot points:

1. Highlight the 'TRK LOG' field setting and press **ENT**.
2. Use the up and down arrow keys to select the desired setting, and press **ENT**.

AutoZoom

AutoZoom automatically changes the map scale to keep your present position and destination on the display at all times. Whenever a GOTO or route is activated, AutoZoom will default to the largest map scale that will fit your present position and 'active to' waypoint. As you head toward the destination, the scale will change to the next lower scale when your present position and the destination can be displayed on that particular scale.

The AutoZoom feature will stop when the scale has reached the 1 nm setting. AutoZoom is designed to allow you to manually change the map scale without turning the automatic map scaling off. In addition, AutoZoom determines whether or not to change the scale based upon the current status of the map:

- If the map scale is manually zoomed in before an AutoZoom takes place, the automatic scaling will resume once it reaches the scale you have selected.

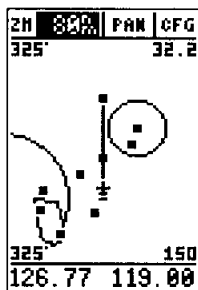

AutoZoom automatically uses the largest scale which will show your current position and the destination waypoint.

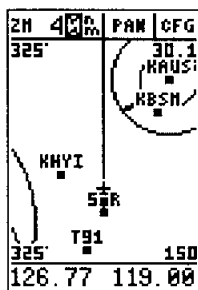

Using the AutoZoom function will allow manual map scale changes without turning automatic map scaling off.

Navigation Page

- If the map scale is manually changed to a setting higher than the current AutoZoom setting, automatic map scaling will be cancelled unless the map scale is manually returned to the current or smaller AutoZoom setting.
- If you leave the map page and miss an automatic scale adjustment, AutoZoom will assume you want to keep the last selected map scale and cancel AutoZoom.
- If the zoom field is active (it has been highlighted and the enter key has been pressed) when the map is ready to scale down to the next level, the AutoZoom feature will be cancelled.

The AutoZoom feature can be turned off through the map configuration setup described on page 58.

Navigation Page

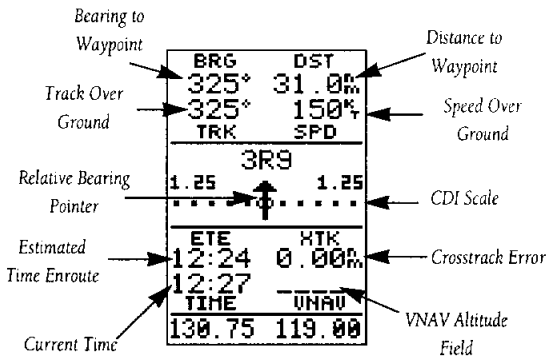

If the GPSCOM 190 is not navigating to a destination waypoint, the navigation page will only display your speed and track over ground.

The navigation page displays the bearing (BRG) and distance (DST) to the destination, along with your present speed (SPD) and track over ground (TRK).

The GOTO destination is listed above the course deviation indicator, with your estimated time enroute (ETE), cross track error (XTK) and time displayed at the bottom of the page.

A relative bearing pointer, located above the CDI scale, points in the direction of your destination.

BRG	DST
356°	150 ⁿ
TRK	SPD
1.25	1.25
.....	
ETE	XTK
11:03	0.00 ⁿ
TIME	VNAV
130.75	124.00

Main Menu Page

Main Menu Page

The GPSCOM 190's main menu page provides access to submenus and functions that are used to select and customize operation and navigation setup. The listings are divided into categories by function. The route management features are discussed on pages 48-51.

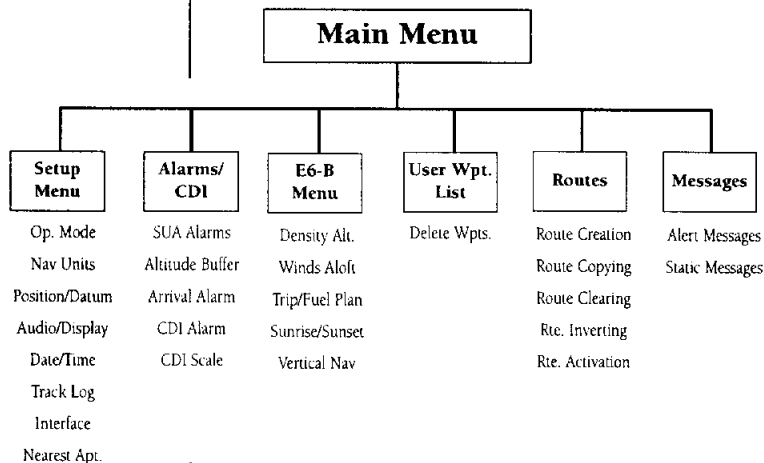

To select a submenu from the main menu page:

1. Highlight the desired setup menu/function.
2. Press **ENT** to display the submenu/function page.
3. To return to the main menu page, press **QUIT**.

The first listing on the main menu page is the setup menu option, which provides access to the setup submenu, where you can select operating modes, display, and other settings to meet your specific preferences. To select a submenu from the setup menu, simply highlight the desired listing and press **ENT**.

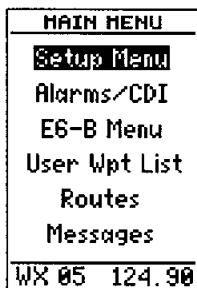

Setup Menu Option

Initial Position Entry

Operational Mode Page

The first setup page is the operational mode page, which is used to select the operating mode and set an initial position reference for initialization or simulator use.

The GPSCOM 190 features three operating modes:

- **GPS Off** disables the unit's GPS functions which will conserve battery life.
- **GPS On** enables the GPS functions of the GPSCOM 190, making it a fully operational unit.
- **Simulator** allows you to operate the unit without acquiring satellites, and is ideal for practicing or entering waypoints and routes while at home.

To select an operating mode:

1. Highlight the 'Current Mode' field and press **ENT**.
2. Use the arrow keypad to choose a mode and press **ENT**.
3. The 'Ref' field will then be highlighted to enable entry of a reference waypoint, if desired. Press **QUIT** to finish.

Initial Position Entry

The initial position field allows you to define a starting point for simulated trips or name an initial position to speed up the acquisition process if the unit has moved more than 500 miles with the power off. When the unit is in simulator mode, you may select a known waypoint as your starting position, or define a distance and bearing from a known waypoint to calculate your starting latitude and longitude.

When the unit is in not in simulator mode, the bearing and distance fields will not be available. Keep in mind that while entering an initial position may speed up acquisition, entering an incorrect initial position will have an adverse effect on the receiver's ability to find the necessary satellites to calculate an accurate position.

To enter an initial position reference:

1. Highlight the 'Ref' field.
2. Enter the identifier of the reference position waypoint and press **ENT**.

OPERATION MODE	
Current Mode: GPS On?	
Initial Position	
Ref: 50R	
Brg: 326°	
Dis: 6.9%	
126.77	119.00

Selecting an operating mode.

OPERATION MODE	
Current Mode: Simulator	
Initial Position	
Ref: 50R___	
Brg: 326°	
Dis: 6.9%	
126.77	119.00

To speed up calculation of the initial position, you may reference an existing waypoint to assist the GPSCOM 190.

Navigation Units

NAV UNITS	
DISTANCE/SPEED:	NM/KNOTS
ALTITUDE:	FEET
TEMPERATURE:	FAHRENHEIT
BARO PRESSURE:	MERCURY
HEADING:	AUTO MAG EDDG
WX 05 124.90	

Nav Units

NAV UNITS	
DISTANCE/SPEED:	NM/KNOTS
ALTITUDE:	FEET
TEMPERATURE:	FAHRENHEIT
BARO PRESSURE:	MERCURY
HEADING:	AUTO MAG EDDG
WX 05 124.90	

Heading Display

If the unit is in simulator mode, the field highlight will advance to the 'Brg' field, where you may define your position in reference to the selected waypoint.

To enter a bearing:

1. With the field highlight on the 'Brg' field, enter a bearing and press **ENT**.

To enter a distance from the reference waypoint:

1. With the field highlight on the 'Dis' field use the alphanumeric keys to enter a distance and press **ENT**.

To exit the operation mode submenu and return to the setup menu press **QUIT**.

Navigation Units

The next setup menu listing is Nav Units where you may select from statute, metric, or nautical navigation units for all speed and distance fields.

To select the navigation units :

1. Highlight the 'DISTANCE/ SPEED' field and press **ENT**.
2. Use the arrow keypad to choose units and press **ENT**.

You can also select the decimal or metric system for the altitude, temperature, and barometric pressure fields using the same method.

Heading Display

Heading information is also displayed on the nav unit submenu. Heading information can be displayed referencing magnetic north (automatic or user-defined), true north or calculated grid headings. The default setting is automatic magnetic north, which is suitable for most applications.

To select a heading preference:

1. Highlight the 'HEADING' field and press **ENT**.
2. Select a heading preference and press **ENT**.

To enter a magnetic heading:

1. Select the 'USER MAG' heading and press **ENT**.
2. Enter the degrees of magnetic variation and press **ENT** to confirm.

Main Menu Options & Settings

Position/Datum

The next setup menu listing is Position/Datum. The default position setting is latitude and longitude in degrees and minutes (hddd°mm.mmm'). You may also select degrees, minutes and seconds (hddd°mm'ss.s'); degrees only (hddd.ddddd°); UTM/UPS coordinates; or Swiss, Swedish, Irish, German, or British Grid formats.

To select a position format:

1. Highlight the 'Posn Format' field and press **ENT**.
2. Select a format and press **ENT**.

Map Datum Setting

The map datum is located just below the heading field, and comes with a WGS 84 default setting. Although 106 map datums are available for use (see the map datum list in Appendix D), you should only change the datum if you are using charts that specify a different datum than WGS 84.

To select a map datum:

1. Highlight the 'Map datum' field and press **ENT**.
2. Use the arrow keypad to toggle through and select the desired setting. Confirm the setting by pressing **ENT**.

Audio/Display Options

The Audio/Display options allows the user to determine the display contrast of the display screen and adjust the backlight timer. The next submenu is the backlight timer. From the timer, you have six different adjustable settings to choose from; 0, 15, 30, 60, 120 and 240 seconds. The submenu tones at the bottom of page allow you to select from three settings; MSG only, MSG and Keystroke, and None. The '0' setting will keep the screen backlighting on as long as the unit is on.

To set the backlight timer:

1. Highlight the 'Backlight Time' field and press **ENT**.
2. Toggle through and select the desired setting. Confirm the setting by pressing **ENT**.
3. To turn backlighting on and off through three levels of lighting, press the backlight button.

POSITION
Posn Format: hddd°mm.mmm'
Map Datum: WGS 84
126.77 119.00

WARNING: Using the wrong map datum can seriously affect the accuracy of your GPSCOM 190.

AUDIO/DISPLAY
Contrast: ██████
Backlight Time: 15 seconds
Tones: Msg & Key
126.77 119.00

Contrast, backlight timer, and tone may be controlled from the audio/display page.

Date & Time Setup

DATE/TIME	
DATE	24 JUN 96
TIME	16:04:04
HOUR FORMAT:	
	24 hour
LOCAL OFFSET:	
	+00:00
TIMER:	
Up	1:29:40
WX 05	124.90

Date/Time setup page

DATE/TIME	
DATE	21 JUN 96
TIME	10:33:21
HOUR FORMAT:	
	24 hour
LOCAL OFFSET:	
	+00:00
TIMER:	
Up	06:32:30
126.77	119.00

To reset the timer, highlight the 'Timer:' field and press the LEFT ARROW key.

To set the screen contrast:

1. Highlight the 'Contrast' field and press **ENT**.
2. Use the right and left keys to adjust the bar scale for the desired contrast and press **ENT**.

The audio/display field lets you specify an audible tone for message alerts and keystroke confirmation.

To select a tone mode:

1. Highlight the 'Tones' field and press **ENT**.
2. Select the desired tone mode and press **ENT**.

Date/Time and Timer Options

The Date/Time submenu provides access to the local time offset and timer functions. The date and time field is located at the top half of the Date/Time page. The time can be displayed in a 12 or 24 hour format.

To set the hour format:

1. Highlight the 'HOUR FORMAT' field and press **ENT**.
2. Use the arrow keypad to toggle through and select the desired setting. Confirm the setting by pressing **ENT**.

The date and time are calculated from satellites and cannot be edited. Because the time shown is UTC time, you will need to enter a time offset to display the correct local time for your area. To determine the time offset for your area, refer to the chart in Appendix E.

To enter the time offset:

1. Highlight the 'LOCAL OFFSET' field.
2. Enter the time offset for your longitude and press **ENT**. Remember to select a positive or negative indicator for your offset (you'll have to move the field highlight to the left of the offset to enter a positive or negative sign for the offset).
3. Press **ENT** to confirm the offset.

The GPSCOM 190's timer function will count down from an entered interval and alert you with a message, or it will keep a running timer that will count up to 99:59:59.

Track Log & Interface Setup

Countdown Timer (cont.)

To set the countdown timer:

1. Highlight the 'Timer' field and press **ENT**.
2. Select the 'Down' setting and press **ENT**. The highlight will advance to the time field.
3. Enter the countdown time (hours, minutes and seconds).
4. Press **ENT** to confirm and begin the countdown.

When the timer expires (at 00:00:00), you will be informed with a message.

The timer will also automatically transition to the count up mode and display how much time has elapsed since the timer expired. The count up timer will keep a running clock until it is manually reset.

To set the count up timer or enter a starting time:

1. With the timer field in the count 'Up' setting, highlight the timer field and press **ENT**.
2. Enter a starting time for the timer. Press **ENT** to finish and restart the timer.

Track Log Options

The next listing on the main menu page is the track log, which lets you manage and erase the GPSCOM 190's tracking data. From the track log page, you can select whether or not to record a track and define how it is recorded.

The track log option sets the number of points the unit will attempt to display on the map page. The maximum setting is 2048 points. Once you've reached the maximum number of track points, the older points will be lost as new points are added. Note that adjusting the track points displayed will not affect whether or not the receiver records a track log or the ability to create a TracBack route. The track log setup page lets you manage the GPSCOM 190's tracking data. From this page, you can select whether or not to record a track and how it is recorded.

DATE/TIME	
DATE	15 JUL 96
TIME	09:02:47
HOUR FORMAT:	
	24 hour
LOCAL OFFSET:	
	-08:01
TIMER:	
Up	17:27:16
130.75	119.92

Setting the count up timer.

TRACK LOG	
RECORD TRACK:	Yes
CRITERIA:	
	Automatic
MEMORY USED	
	0% 9 OF 2048 PNTS
TRACBACK?	
	CLEAR TRACK LOG
126.77	119.00

Track Log Page

Clear the track log to unclutter the screen or to begin a TracBack.

Track Log Setup

TRACK LOG	
RECORD TRACK:	Yes
CRITERIA:	
Time Interval:	00:00:30
MEMORY USED	0%
10 OF 2048 PNTS	
TRACBACK?	
CLEAR TRACK LOG?	
126.77	119.00

You may select how often track points are laid down, which will effect the display on the map page.

CLEAR TRACK LOG	
WARNING!	
all track log points will be deleted	
Are you sure	
Yes?	or No?
126.77	119.00

To clear the track log, highlight the 'Yes?' prompt and press ENTER.

Track Log (cont.)

To turn the track log on or off:

1. Highlight the 'RECORD TRACK' field and press **ENT**.
2. Select 'Yes?' or 'No?' and press **ENT**.

NOTE: Turning the track recording off will disable the TracBack feature.

The stored track criteria determines how often positions are stored in the track log. The default setting is automatic, and stores tracks based on resolution. This setting gives you the most efficient use of track memory and provides the most accurate TracBack route.

To change the criteria to record points based upon a specific time interval:

1. Highlight the 'CRITERIA' field and press **ENT**.
2. Select 'Time Interval' and enter a value in hours, minutes and seconds. Press **ENT**.

The rest of the track log setup page displays the percentage of memory used to store the current track log data and contains function fields used to clear the track log memory and activate the TracBack feature.

To clear the track log:

1. Highlight 'CLEAR TRACK LOG?' and press **ENT**.
2. A warning page will appear, asking you to confirm your actions. Highlight 'Yes?' and press **ENT**.

TracBack Function

The last option on the track log options page is the TracBack function which lets you activate a TracBack route using the track log (see pages 45-46 for more information.)

To activate a TracBack route:

1. Highlight 'TRACBACK?' and press **ENT**.

Interface Setup

Interface Setup

The Interface Setup page lets you specify the interfacing formats for connecting external NMEA devices, a DGPS receiver, or a personal computer. The 'Input/Output Format' field, at the top of the page, lets you specify one of six formats (input first followed by output):

- **'GRMN/GRMN'** is a proprietary interface that allows you to exchange data such as waypoints, routes and track logs between the GARMIN GPS units and a GARMIN PC kit.
- **'NONE/NMEA?'** provides navigation information to a compatible NMEA device such as an autopilot or radar. NMEA 0180, 0182, 0183 v. 1.5 and 0183 v. 2.0 output options are available.
- **'NMEA/NMEA?'** allows input from a NMEA compatible device, with selectable NMEA output.
- **'RTCM/NMEA?'** allows DGPS beacon receiver input and also provides selectable NMEA output.
- **'RTCM/NONE?'** allows DGPS beacon receiver input without output capabilities.
- **'NONE/NONE?'** provides no interfacing capabilities.

To select an I/O format:

1. Highlight the I/O field and press **ENT**. Toggle through and select the desired setting, and press **ENT**.

The GRMN/GRMN setting is a proprietary format that lets you exchange user data between GARMIN GPS units or a PC with an optional GARMIN PC kit. During data transfer, the number of packets being exchanged will be displayed on screen.

To select a transfer option:

1. Highlight the 'Host' field and press **ENT**.
2. Select the desired setting and press **ENT**.

To disable all GPSCOM 190 interfacing capabilities, select the None/None setting. If you want to output NMEA data to compatible external devices without any differential input capability, select the NONE/NMEA setting.

INTERFACE	
NMEA /NMEA	
NMEA 0183 2.0	
4800 baud	
130.75	119.00

Once an NMEA interface option is chosen, 0183 version 2.0 with a baud rate of 4800 will automatically be selected.

INTERFACE	
GRMN/GRMN	
Host	
Waiting...	
---- of ----	
PACKETS	
130.75	119.92

Selecting a transfer option.

DGPS Interface Setup

INTERFACE	
RTCM/NMEA	
NMEA 0183 2.0	
4800 baud	
BEACON RECEIVER	
FREQ:	100.0kHz
RATE:	250bps
DIST	--NM
SMR	--dB
No Status	
130.75	119.00

DGPS Interface

Once an RTCM interface option is selected, you must manually tune the beacon receiver from the frequency field.

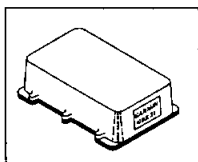

DGPS corrections are accepted on RTCM-104 v. 2.0 format. The GARMIN GBR 21 is the recommended beacon receiver for use with the GPSCOM 190. Other receivers with the correct RTCM format may be used, but may not correctly display status or allow tuning control.

Once a NMEA setting has been selected (with or without RTCM input), the NMEA setting of 0183 version 2.0 with a baud rate of 4800 will automatically appear and is not selectable.

DGPS Interface Setup

The two RTCM settings allow the GPSCOM 190 to accept DGPS corrections in RTCM 104 version 2.0 format. The RTCM/NONE format will allow you to connect any manually-tuned beacon receiver to the proper interface, with the baud rate selectable from the GPSCOM 190. The RTCM/NMEA selection controls the GARMIN GBR-21 beacon receiver.

Once a RTCM setting has been selected, the GPSCOM 190 will automatically try to tune the last frequency and bit rate selected, or it will switch to the default frequency of 304.0 kHz with a bit rate of 100 bps if no previous beacon has been tuned. You may also enter your own frequency and bit rate if desired.

To enter a DGPS beacon frequency:

1. Highlight the 'FREQ' field.
2. Enter the desired frequency and press **ENT**.
3. Highlight the 'RATE' field and press **ENT**.
4. Select the rate and press **ENT**.

When the GPSCOM 190 is receiving DGPS corrections, the 'beacon receiver' section of the I/O setup page will display the frequency and signal strength, as well as the distance from the transmitter to the beacon receiver. A status message will constantly keep you informed of DGPS activity:

- A 'tuning' message will be displayed while a beacon signal is being tuned. Once the signal has been tuned, the message 'receiving' will be displayed.
- If a signal is tuned and no corrections are being received, a 'no data' message will be displayed.
- If a beacon signal cannot be tuned, a 'no status' message will be displayed.

Nearest Airports

Nearest Airports

The last listing on the setup menu is nearest airports, which allows you to define the type and minimum length of runway used to calculate the nearest airports. The options for runway surfaces are:

- **Any:** (Default setting) any runway, regardless of surface type, including water landing facilities.
- **Hard Only:** Only runways with a concrete, asphalt or similar sealed surface.
- **Hard or Soft:** All runways except water landing.
- **Water Only:** Only water landing facilities.

To select a runway surface:

1. Highlight the runway surface field and press **ENT**.
2. Select the surface and press **ENT**.

The nearest airport page allows you to designate a minimum runway length used to determine the nine nearest airports. The default setting is zero feet.

To enter a minimum runway length:

1. Highlight the 'Minimum Length' field and press **ENT**.
2. Enter the desired runway length and press **ENT**.

Updating the GPSCOM 190 Database

The GPSCOM 190's internal worldwide Jeppesen database may be updated from a PC computer using GARMIN's optional PC Database Update Software and an interface cable. Updates are available from Jeppesen or GARMIN on a subscription or one time basis. Information describing the update instructions is provided with each GARMIN PC software kit.

NEAREST APT	
Runway Surface:	Any
Minimum Length:	0000
	126.77 119.00

Selecting a minimum runway length.

AMERICAS SUN CYCLE 9607 EFFECTIVE 20 JUN 96 TO 18 JUL 96

After the database update is completed, the GPSCOM 190 will automatically display the database page.

Alarm and CDI Functions

The second option available on the GPSCOM 190's main menu page is the Alarms/CDI submenu, which is used to control SUA alarms, set arrival and CDI alarms and define the course deviation indicator scale.

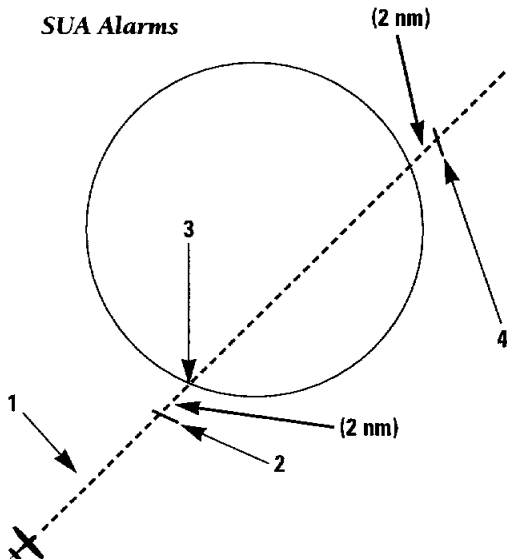

SUA Alarms

The GPSCOM 190's special use airspace feature will inform you if any restricted or controlled airspace is near or in your flight path, according to the following conditions:

1. If your projected course will take you inside an SUA within the next 10 minutes, a **'SUA ahead < 10 min'** message will be displayed.
2. If you are within 2 nm of an SUA and your current course will take you inside, a **'SUA near & ahead'** message will be displayed.

SUA Alarms

3. If you have entered an SUA, a **'Inside SUA'** message will be displayed.
 4. If you are within 2 nm of an SUA and your current course will not take you inside the airspace, a **'Near SUA < 2nm'** will be displayed.
- All SUA alerts are based on your present GPS altitude.

The GPSCOM 190's SUA alarms for the following airspace types may be turned on or off from the alarms/CDI page:

- Class B/CTA- ICAO Control Area
- Class C/TMA- ICAO Terminal Control Area
- Other CTRL- Other Controlled Airspaces such as control tower airspace, control zones, and tower SUAs
- MOA- Military Operations Area
- Restricted- Restricted areas
- Other SUA- Other airspaces, including alert, caution, danger and warning areas

Turning SUA Alarms On & Off

Alarm warnings for prohibited areas may not be turned off. Turning a warning 'off' from the alarms/CDI page will only prevent the you from receiving a message alert for an airspace. SUA information will still be displayed on the map page unless that category is turned off from the map configuration page.

To turn an SUA category on or off:

1. Highlight the desired SUA category and press **ENT**.
2. Select 'On' or 'Off'.
3. Press **ENT**.

ALARMS/CDI	
CLASS B/CTA:	ON
CLASS C/TMA:	ON
OTHER CTRL:	ON
MOA:	ON
RESTRICTED:	ON
OTHER SUA:	ON
ALT BUF:	200FT
ARRVL:	0.0NM OFF
CDI ALARM:	OFF
SCALE:	0.0NM ±1.25
130.75 119.00	

Turning an SUA alarms category off.

Altitude Buffer/Arrival Alarms

ALARMS/CDI	
CLASS B/CTA:	ON
CLASS C/TMA:	ON
OTHER CTRL:	ON
MOA:	ON
RESTRICTED:	ON
OTHER SUA:	ON
ALT BUF:	0200FT
ARRUL:	0.0NM OFF
CDI ALARM:	OFF
	0.0NM
SCALE:	±1.25
130.75	119.00

Setting an altitude buffer.

ALARMS/CDI	
CLASS B/CTA:	ON
CLASS C/TMA:	ON
OTHER CTRL:	ON
MOA:	ON
RESTRICTED:	ON
OTHER SUA:	ON
ALT BUF:	200FT
ARRUL:	10.0NM OFF
CDI ALARM:	OFF
	0.0NM
SCALE:	±1.25
130.75	119.00

The arrival alarm can be used to notify you when you have reached a set distance from a destination waypoint.

Altitude Buffer

The 'ALT BUF' field, located directly below the Other SUA alarm settings, is an altitude buffer that allows you to set a specific altitude range for triggering SUA alerts. This helps add an extra margin of safety to your estimated altitude error to ensure you receive SUA messages in time to avoid unwanted SUA intrusions. The default altitude buffer is 200 feet.

The value of the altitude buffer is added to an estimated altitude error calculated by the GPSCOM 190. This value is then added or subtracted from your present GPS altitude. If the final adjusted altitude falls within an SUA, you'll receive a message. If the adjusted altitude does not place you in an SUA, you won't receive the message.

To enter an altitude buffer:

1. Highlight the 'ALT BUF' field. Enter a buffer value and press **ENT**.

Arrival Alarms

The next function available from the alarms/CDI page is the waypoint arrival alarm, which will activate an alarm message once you've come within a set distance of a destination waypoint. Three options are available:

Off- No arrival alarm will sound.

Auto- An arrival alarm will sound one minute before the destination, based upon your current speed and course.

On- An arrival alarm will sound at the alarm distance specified in the distance field for the destination waypoint.

(The 'On' setting will only provide an arrival alarm for the final destination waypoint of the active route).

To set the arrival alarm:

1. Highlight the arrival distance field and press **ENT**.
2. Enter a distance (up to 99.9 nm).
3. Press **ENT** to select the arrival field.
4. Use the arrow keys to select 'ON', 'Off', or 'Auto' and press **ENT**.

CDI Alarm & Scale

The last section of the alarms/CDI page allows you to set a CDI/crosstrack alarm and define the course deviation indicator scale. The CDI alarm will provide a message when your crosstrack error exceeds a specified distance.

To set the CDI alarm:

1. Highlight the 'CDI ALARM' field and press **ENT**.
2. Select 'ON'.
3. Enter a distance (to 99.9 nm) and press **ENT**.

The CDI scale field lets you select the +/- range of the CDI bar scale that appears on the nav page. Three scales are available: +/- 0.25, 1.25 and 5.0 miles or kilometers, with 1.25 being the default setting.

To select a CDI scale:

1. Highlight the 'SCALE' field and press **ENT**.
2. Use the arrow keypad to select a scale and press **ENT**.

E6-B Menu

The third listing on the main menu page is the E6-B menu, which provides access to the GPSCOM 190's density altitude and winds aloft functions. The E6-B menu also allows access to trip and fuel usage, sunrise and sunset, and vertical navigation profiles.

To calculate density altitude and true air speed:

1. Highlight the indicated altitude field 'Alt'.
2. Enter the altitude from your altimeter and press **ENT**. The highlight will move to the 'CAS' field.
3. Enter the calibrated airspeed and press **ENT**. The highlight will move to the 'Prs' field.
4. Enter your current altimeter setting and press **ENT**. The highlight will move to the 'TAT' field.
5. Enter the TAT (reading from standard outside air temperature gauge on most piston aircraft) and press **ENT**. The calculated density altitude and true airspeed will be displayed at the bottom of the page.

CDI Alarm & E6-B Menu

ALARMS/CDI	
CLASS B/CTA:	ON
CLASS C/TMA:	ON
OTHER CTRL:	ON
MON:	ON
RESTRICTED:	ON
OTHER SUA:	ON
ALT BUF:	200FT
ARRVL:10.0NM	OFF
CDI ALARM:	OFF
SCALE:	±1.25
130.75	119.00

The CDI alarm will alert you if you are off course by more than the selected scale.

MAIN MENU
Setup Menu
Alarms/CDI
E6-B Menu
User Wpt List
Routes
Messages
130.75 119.00

Highlight 'E6-B Menu' and press **ENTER** to access navigation utilities such as trip and fuel usage and vertical navigation profiles.

Trip & Fuel Planning

WINDS ALOFT	
TAS:	156%
Hdg:	225°
Head Wnd 6.0%	
Wind from 331°	
at 6.0%	
126.77	119.00

Winds aloft may be calculated by entering your true air speed and current heading.

TRIP & FUEL PLAN	
Waypoint	
From:	KCOS
To:	KIXD
Speed:	150%
Flow:	11
DTK	077°
DIS	460%
REQ	34
ETE	03:04
126.77	119.00

Navigational information and fuel usage may be calculated for a trip between any two waypoints.

Winds Aloft Function

The GPSCOM 190's winds aloft function will calculate the wind direction, speed and head/tail wind conditions for the aircraft once you have entered your true air speed and current heading.

To calculate winds aloft:

1. Highlight the true airspeed field 'TAS'.
2. Enter the TAS (use the density altitude function if you do not know TAS) and press **ENT**.
3. Press **ENT** to begin entry of your current heading (Hdg).
4. Enter your heading and press **ENT**. The wind direction, speed and the head/tail wind conditions will be displayed at the bottom of the page.

Trip and Fuel Planning Function

The GPSCOM 190's trip and fuel planning function will calculate the desired track, distance, estimated time enroute and fuel requirements between any two waypoints or any programmed route. The first field (top left of the planning page) allows you to select between waypoint or route planning.

To perform a waypoint-to-waypoint trip and fuel plan:

1. Highlight the Waypoint/Rte field and press **ENT**.
2. Use the arrow keypad to select the 'Waypoint' option and press **ENT**. The field highlight will move to the 'From' field.
3. Enter the starting waypoint for the trip, or leave the field blank to start from your present position, and press **ENT**. The field highlight will advance to the 'To' field.
4. Enter the destination waypoint and press **ENT**. The field highlight will advance to the 'Speed' field.
5. Enter trip speed and press **ENT**. The field highlight will advance to the 'Flow' field.
6. Enter the fuel flow for the trip and press **ENT**. The desired track (DTK), distance (DIS), fuel requirement (REQ), and estimated time enroute (ETE) of the trip will be displayed at the bottom of the page.

Route Planning

Route Planning

The route planning function will calculate trip information for any programmed route and provide data on both the entire route and each individual route leg.

To perform a route trip and fuel plan:

1. Highlight the Waypoint/Rte field and press **ENT**.
2. Select the 'Rte' option and press **ENT**. The field highlight will move to the route number field.
3. Press **ENT** to begin selection of the desired route.
4. Enter the route number and press **ENT**. The field highlight will advance to the 'Leg' field. Select either 'All' or a specific route leg (Leg 1, etc.) to calculate, and press **ENT**.
5. Enter the route or leg speed and press **ENT**. The field highlight will advance to the 'Flow' field.
6. Enter the fuel flow for the route or leg and press **ENT**.

The GPSCOM 190 will display the distance, fuel requirement and estimated time enroute for the route or route leg, and provide the desired track for each leg.

Sunrise/Sunset Calculator

The next E6-B function available is the sunrise/sunset calculator, which will allow you to calculate the sunrise and sunset for any known waypoint or your present position for a specific date.

To calculate sunrise/sunset information:

1. Highlight the waypoint field.
2. Enter the desired waypoint, or leave the waypoint field blank to calculate the sunrise/sunset for your present position, and press **ENT**. The field highlight will automatically advance to the date field.
3. Enter the day of the month, 3 letter month abbreviation, and the two digit year abbreviation. The default date will be the current date as calculated by the GPS satellites.
4. Press **ENT**. The sunrise and sunset for the entered date will be displayed at the bottom of the page.

TRIP & FUEL PLAN	
Rte 1 Leg 1	
From: KOJC	
To: KMKC	
Speed: 150k	
Flow: 0	
DTK 018°	
DIS 17.8%	
REQ 0	
ETE 07:08	
126.77	119.00

If your flight will follow an existing route, you may calculate trip and fuel information for individual legs or the entire route.

SUNRISE/SUNSET	
Waypoint:	
<input checked="" type="checkbox"/> MKH__	
Date:	
21 JUN 96	
Rise 11:30:18	
Set 01:34:39	
126.77	119.00

Sunrise and sunset for any waypoint or your current position may be determined by using the sunset/sunrise calculator.

Vertical Navigation

Vertical Navigation Function

The last option featured on the GPSCOM 190's E6-B menu is the vertical navigation (VNAV) function, which lets you create a rate of descent profile from your present position and altitude to a final altitude at a specified location. To use the VNAV feature, your aircraft's ground speed must be greater than 35 knots, and you must be navigating an active GOTO or route.

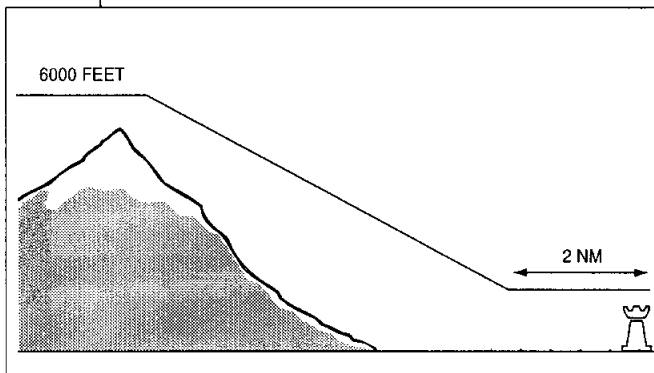

To perform a VNAV calculation:

1. Highlight the 'From' field.
2. Enter the initial altitude and press **ENT**.
3. Enter the final 'To' altitude.
4. Enter the offset (the distance from the waypoint you'll be referencing for your final altitude) and press **ENT**.
5. Select the 'Before' or 'After' option for the distance offset and press **ENT** to confirm.
6. Enter the waypoint you want to use as a reference for your final altitude. If you are navigating an active route, the waypoint field will offer the active-to waypoint for the reference waypoint (the waypoint page will appear for you to confirm).
7. Press **ENT** to confirm the waypoint. The vertical speed for the descent will appear in the 'At' field.

Vertical Navigation Function (cont.)

To activate the VNAV function:

1. Review the calculated vertical speed. If the calculated speed does not fit within the performance guidelines of your aircraft, manually enter the appropriate speed in the 'At' field and press **ENT**.
2. Highlight the 'Vnav' field and press **ENT**.
3. Select the 'On' setting and press **ENT**.

The VNAV status at the bottom of the page will change from 'Enter Profile' to 'Begin In _____', indicating the time remaining to begin the descent. Once you are less than 15 seconds from the starting point of the descent, you'll be informed with a 'Start Altitude Change' message.

If the maneuver has already started, the status field will display a 'Navigating' status.

While the VNAV function is active, the vertical navigation page will provide a continuous display of the recommended altitude you should be at (the 'From' field) and the vertical speed required (the 'At' field) to complete the maneuver.

When the recommended altitude is within 1,000 feet of the final altitude, you'll be informed with a 'Final Altitude Alert' message. The recommended altitude during any active VNAV maneuver is also displayed at the bottom right of the Navigation Page.

The VNAV function will be cancelled automatically if the active route or GOTO is changed in any way (e.g., performing an on-route GOTO or adding a waypoint to a route). Whenever this happens, you'll be informed with a 'VNAV Cancelled' message.

If your current speed does not exceed 35 knots, or a route waypoint that has already been past is selected, the status line will display 'Invalid Profile'. If there is no active GOTO or route, the status field will display 'No Active Waypoint'.

VNAV Function

VERTICAL NAV	
From:	2479f
To:	3500f
By:	3.0%
Before	
Wpt:	3R9
At:	17fpm
Vnav:	Off
Enter Profile	
126.77	119.00

While on an active GOTO, you may create a vertical decent profile by using the VNAV function.

VERTICAL NAV	
From:	3465f
To:	3500f
By:	3.0%
Before	
Wpt:	3R9
At:	17fpm
Vnav:	On
Navigating	
126.77	119.00

Once the VNAV function has been initiated, a 'Navigating' status will appear at the bottom of the page.

User Waypoint List

```

WAYPOINT LIST
246 EMPTY 5 USED
GARMIN
MAP
T001
T002
T003
-----
DEL ALL WPTS?
130.75 119.00
  
```

The GPSCOM 190 can store up to 250 user waypoints. To view a specific user waypoint page, highlight the waypoint name and press ENTER.

User Waypoint List

The last three options on the main menu are the user waypoint list, routes, and messages. The user waypoint list provides you with a complete list of all user waypoints stored in the GPSCOM 190. The total number of used and empty waypoints is indicated at the top of the page. From the user waypoint list, you can quickly GOTO a selected waypoint, review a selected waypoint's waypoint page or delete all user waypoints.

To select a waypoint as a GOTO destination:

1. Highlight the desired waypoint and press **GOTO FIRST**.
2. Press **ENT** to activate the GOTO.

To review the waypoint page of a listed waypoint:

1. Highlight the desired waypoint and press **ENT**.
2. To return to the waypoint list, press **ENT** again.

```

DELETE ALL WPTS
WARNING!
all user defined
waypoints and
routes will be
deleted
Are you sure
Yes? or No?
126.77 119.00
  
```

To delete all user waypoints:

1. Highlight 'DELETE ALL WPTS?' and press **ENT**.
2. Highlight 'Yes?' and press **ENT**.

Routes Submenu

The routes option is covered in the routes section on page 47.

Messages Page

The message page displays all current messages in the GPSCOM 190. There are two types of messages: temporary alerts (e.g., approaching a waypoint) and condition alerts (e.g., battery power is low). All messages are initially indicated by a flashing on-screen indicator.

After a temporary alert has been viewed, it is cleared from the message page. Condition alerts are displayed on the messages page until the condition has been resolved. For a complete list of messages, see Appendix C.

MESSAGES	
No DGPS	
Position	
PRESS PAGE	
130.75	119.00

To view the messages page:

1. Highlight the 'Messages' field and press **ENT**. To return to the main menu page, press **PAGE**.

Universal Yoke Mount

The GPSCOM 190 includes an adjustable yoke mount that may be attached to the control yoke for easy access without blocking the view of the instrument panel. The clamp that comes with the standard yoke mount is configured to the control yoke of more than 90% of general aviation aircraft.

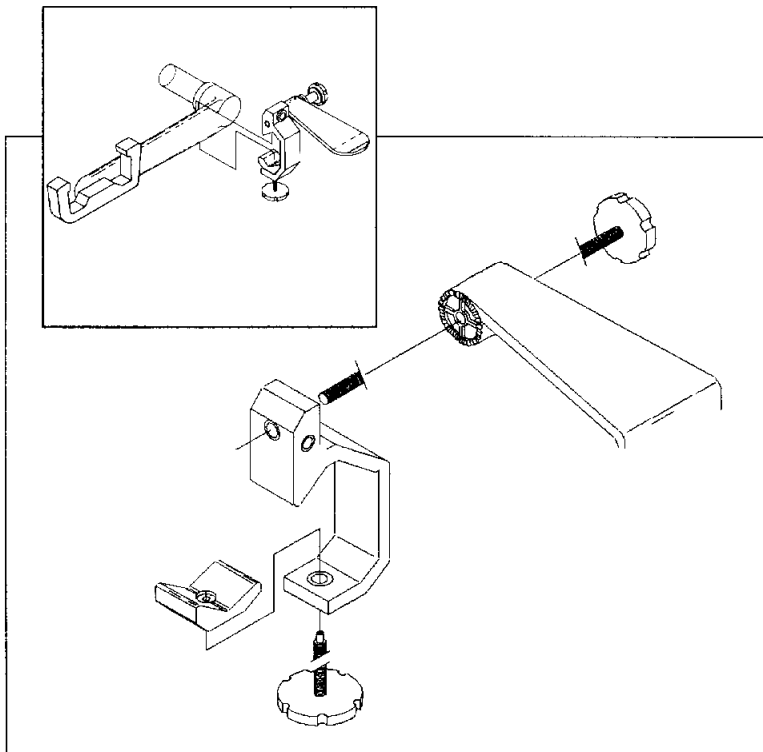

To attach the yoke mount to the control yoke:

1. Loosen the lower knob.
2. Slide the clamp over the control yoke shaft just behind the control wheel.
3. Tighten the lower knob securely.
4. Make sure that the clamp is as close as possible to the control wheel and check to make sure that the yoke travel is not limited or hindered in any way by the yoke mount.
5. If it is necessary to change the direction of the clamp, completely loosen and remove the upper knob, then mate up the appropriate sets of teeth so the clamp opens to the left or right (for conventional yokes), or toward the instrument panel (for Baron or Bonanza yokes or conventional control arms.)
6. Tighten the upper knob.
7. Loosen the clamp adjustment knob enough to slide the clamp over the control yoke shaft or arm.
8. Tighten the clamp over the control yoke shaft or arm using the clamp adjustment knob.

The yoke includes a bracket holder which is used to secure the GPSCOM 190 during flight and a bracket extension which can be used to conveniently attach the headset/microphone adapter.

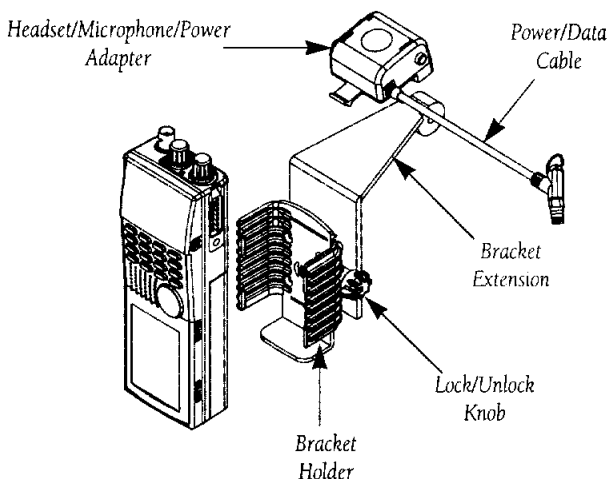

To secure the GPSCOM 190 using the bracket holder:

Note: The unit is most easily inserted and removed from the top of the bracket holder.

1. Slightly spread the sides of the bracket holder and insert the unit, mating the four notches on the sides of the unit with the four tabs on the bracket holder. Lock the unit in place by pushing in and turning the lock/unlock knob located on the side of the bracket holder to the lock position. Note: when removing the unit, push in and turn the knob to the unlock position and lift the unit out.
2. If desired, slide the headset/microphone adapter case over the bracket extension until the case is securely held in place.
3. If it is necessary to change the angle of the bracket for proper viewing angle, loosen the upper bracket knob and rotate the GPSCOM 190 up or down, then re-tighten the orientation knob.

Headset/Microphone/DC Power Adapter

A combination headset/microphone may be plugged into the speaker/microphone jacks located on the speaker/microphone/power adapter which is supplied with the GPSCOM 190. The adapter also provides a convenient means of connecting the 12-24 VDC aircraft or automobile adapter that plugs into a cigarette lighter and allows you to run the GPSCOM 190 from aircraft or automobile power.

NOTE: The cigarette lighter adapter cannot be used to charge the Ni-Cad battery pack when the unit is on.

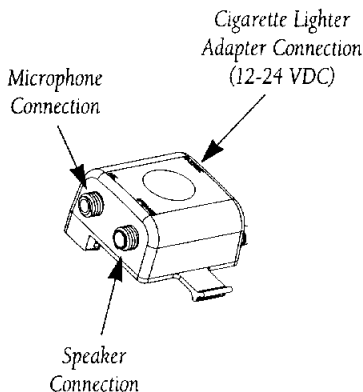

The cable which is hardwired to the adapter connects to the power/data connector which is located on the right side of the GPSCOM 190.

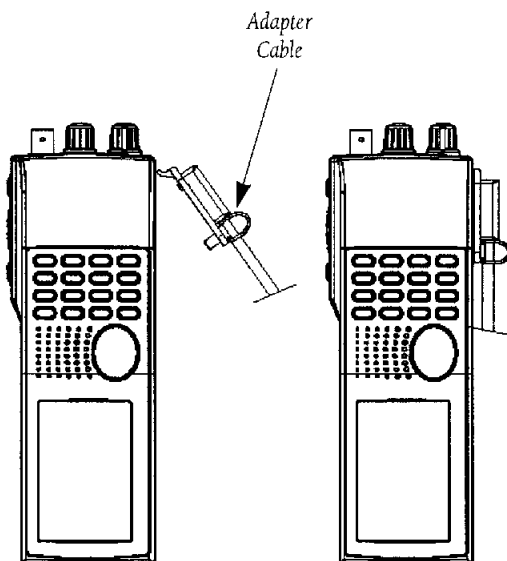

To connect the adapter cable to the GPSCOM 190:

1. Insert the top lip of the adapter cable into the recess located above the power/data connector.
2. Using the attached ring, insert the fastener located at the bottom of the adapter cable into the hole located below the power/data connector and turn clockwise until the adapter cable is locked in place (approximately one quarter turn.)

Remote GPS Antenna

The GPSCOM 190 includes a GARMIN GA 27 remote GPS antenna which can be used to enhance satellite reception. Simply plug the "MCX" male connector on the end of the GA 27 cable into the socket located on the side of the GPSCOM 190. Place the antenna in view of satellites, and the system is ready for operation. The GA 27 can be mounted using the suction cup mount, which is included with the antenna. When mounting, you must ensure that the antenna's location provides an unobstructed view of much of the sky. This is critical to allow the antenna to "see" at least four satellites in order to compute your position and track your flight.

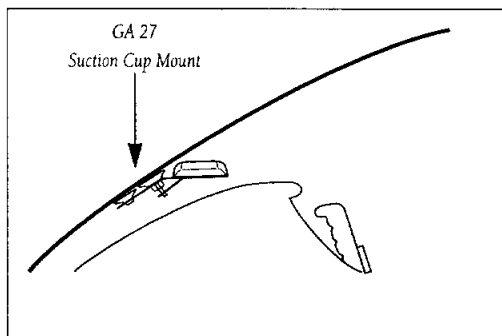

To use the suction cup mount:

1. Attach the suction cup mount to the bottom of the GA 27 antenna using the two flat head screws (provided). Position the antenna as low as possible on the windshield to maximize satellite visibility and not obstruct your view of the sky.
2. The suction cup mount can be adjusted to compensate for aircraft windshields of varying angles. The adjustment is made by rotating the large suction cup until the proper angle for mounting is obtained.

Accessories & Installation

A variety of other accessories are included with the GPSCOM 190:

Carrying Case

A durable nylon carrying case comes with a belt attachment on the back. A side pocket is included for easy storage of the com antenna.

Belt Clip

The GPSCOM 190 includes a sturdy belt clip so you can carry the unit with you wherever you go. To attach the clip you will need to remove the rubber bumper from the back of the unit. Attach the clip using the two screws just removed from the bumper as shown in the figure below.

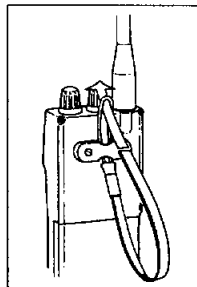
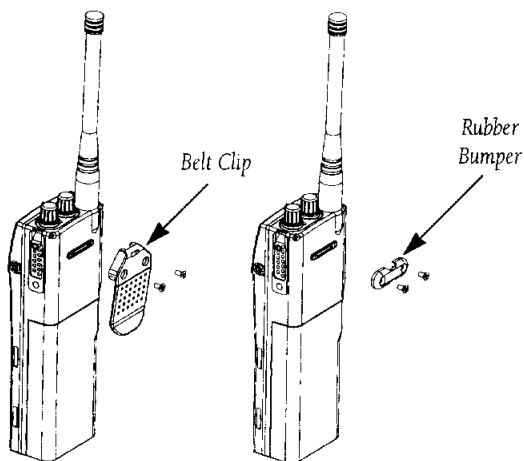

To attach the wrist strap, thread the strap through the slot in the rubber bumper or the belt clip. Next, take the solid end of the strap, insert it through the eye of at the other end, and tighten.

Flex Com Antenna Removal

To remove the flex com antenna:

1. Squeeze the base of the antenna and turn counter-clockwise until the antenna disengages from the connector on the unit.
2. Pull up gently and remove.

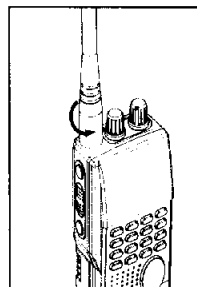

Removing the flex com antenna.

Battery Pack Removal

To remove the Ni-Cad battery pack:

1. Press down on the battery pack latch, pull down on the pack and remove.

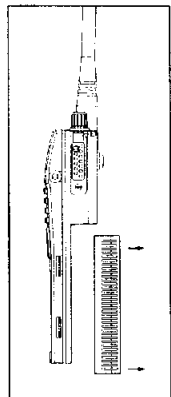
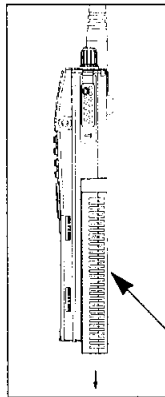
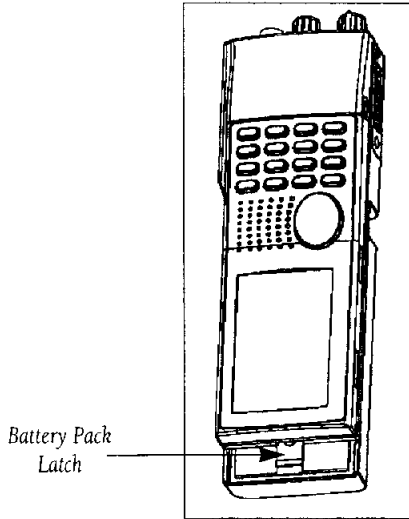

*Battery Pack
Removal*

Accessories & Installation

Trickle Charger/AC Adapter

The trickle charger/AC adapter supplied with the GPSCOM 190 converts line voltage to the DC voltage necessary to operate the unit. The adapter also slowly recharges the Ni-Cad battery pack at a rate of 14 hours for a full recharge. Make sure you charge the Ni-Cad battery pack for 14 hours before using your GPSCOM 190 to ensure optimum capacity and performance. When charging the battery pack, be sure to turn the unit off to ensure a full charge. Note that the cigarette lighter adapter will not trickle charge the battery pack.

To recharge the Ni-Cad battery pack:

1. Attach the connector end of the adapter to the GPSCOM 190 by sliding it into the slot on the left side of the unit (observe the keyway on the unit connector and the matching groove on the connector end).
2. Plug the other end into an electrical outlet.



Do not charge the GPSCOM 190 for more than 24 hours. Heat generated by overcharging can shorten battery life and cause battery pack component failures.

WARNING!

Do not dispose of a Ni-Cad battery pack in a fire or incinerator. Heat may cause battery cells to explode and/or release dangerous gases. All batteries must be recycled or disposed of properly, and cannot be disposed of by ordinary waste disposal methods. Please take the time to check with your nearest GARMIN service center for proper disposal methods and locations.

Battery Pack Handling and Storage

The Ni-Cad battery supplied with the GPSCOM 190 has exposed terminals which may be shorted if not stored properly. Don't place a loose battery pack on or near metal objects (paper clips, keys, tools, etc.) and be careful when placing battery packs in handbags, toolboxes, etc. Never immerse a battery pack in water. If the battery pack becomes wet, wipe it dry before attaching it to the unit.

Always store your GPSCOM 190 with the battery pack installed. An internal lithium battery will save almanac and waypoint data for an extended period of time, but it is designed to allow you to recharge the battery pack, not replace it. If you're storing the unit for the season, make sure the batteries are fully charged.

Specifications

The GPSCOM 190 is constructed of high-quality materials and should not require user maintenance. Should your unit ever need repair, please take it to an authorized GARMIN service center. The GPSCOM 190 has no user-serviceable parts. Never attempt any repairs yourself. To protect your GPSCOM 190, keep it in its carrying case when not in use, and never allow gasoline or other solvents to come into contact with the case. Clean the case and lens with a soft cloth and a household window cleaner.

PHYSICAL

Size:	7.1"H x 2.3"W x 1.4"D (18 x 5.8 x 3.6 cm)
Weight:	Approx 1.4 lbs. (.63Kg)
Temperature Range:	5° to 158°F (-15° to 70°C)

PERFORMANCE

GPS:	Receiver:	PhaseTrac12™
	Acquisition Time:	Approx. 15 seconds (warm start) Approx. 45 seconds (cold start) Approx. 5 minutes (AutoLocate)
	Update Rate:	1/second, continuous
	Position Accuracy:	1-5 meters (16-33 ft.) with DGPS corrections* 15 meters (49 ft.) RMS**
	Velocity Accuracy:	0.1 knot RMS steady state
	Dynamics:	Performs to specification to 6g's

Transceiver:	Operating Temp:	5° to 158°F (-15° to 70°C)
	Frequency Range:	108.000 to 136.975 MHz Aviation, 161.650 to 163.275 MHz Weather
	Selectivity:	Adjacent channel rejection, 70dB Spurious Image Response, 70dB
	Sensitivity (AM):	> 6 dB SINAD at 1 microvolt hard
	(WX):	> 12 dB SINAD at .5 microvolt hard

Specifications subject to change without notice.

* With optional GARMIN GBR 21 Beacon Receiver Input.

** Subject to accuracy degradation to 100m 2DRMS under the US DOD-imposed Selective Availability Program.

Transceiver Specifications (continued):

Adjacent Channel Rejection:	> 70 dB down
Channel Spacing:	25 kHz (COM), 50 kHz (NAV)
Audio Power:	7 vPP across 300 ohm load
Audio Distortion:	< 15%
Transmitter Output:	1.5 Watts nominal
Sidetone Audio Power:	7 vPP across 300 ohm load
Distortion:	Total Harmonic Distortion < 15%
Frequency Stability:	+/- 300 Hz
Duty Cycle:	No damage even if continuously keyed
Microphone:	Internal electret or optional external mic/headset
Compliance:	FCC Part 87

POWER

Input:	(1) 7.2 volt external Ni-Cad battery pack.
Battery Life:	GPS on, Com on with 5% xmit @ 1.5 watts & 95% receive: 3.5 hours GPS off, Com on with 5% xmit @ 1.5 watts & 95% receive: 5.5 hours GPS on, Com on with receive only: 6-7 hours GPS on, Com off: 14.5 hours

Messages

The GPSCOM 190 uses a flashing on-screen message indicator to alert you to important information. Whenever the message indicator appears, press **PAGE** to view the message page. There are two types of messages: temporary alerts and condition alerts. Temporary alerts are cleared from the message page after viewing, while condition alerts remain until the condition has been resolved. Pay careful attention to all messages for your own safety.

Accuracy has been Degraded—The accuracy of the receiver has been degraded beyond 500 meters due to poor satellite geometry or data quality. You should check other navigational sources to verify the position indicated.

Active Waypoint Can't Be Deleted—You have attempted to change the 'Active To' or 'Active From' waypoint. Clear the active route or GOTO before making your changes.

Already Exists—The name you are entering already exists in memory.

Approaching—You are one minute away from reaching a destination waypoint.

Arrival At—You are within the arrival alarm circle of the indicated waypoint.

Battery Power is Low—The Ni-Cad battery is low and should be recharged.

Battery Power is too Low to Transmit—Battery power is too low to allow transmitting.

Cannot Navigate Locked Route—You have attempted to navigate a route with a locked waypoint. A waypoint can be 'locked' when the database is updated if the waypoint does not exist in the new database.

CDI Alarm—Your course deviation has exceeded the limit specified on the alarms setup page.

COM Failed—The VHF com has failed. Take the unit to an authorized service center.

Database Memory Has Failed—The internal memory for the Jeppesen database has failed. Take the unit to an authorized GARMIN service center.

Final Altitude Alert—The current altitude is within 1000 feet of the final altitude entered on the VNAV page.

GPS and COM Turned Off—The GPS and Com functions are turned off due to low battery voltage.

Inside SUA—Your aircraft has entered the boundaries of special use or controlled airspace.

Leg Not Smoothed—The upcoming route leg is too short for smooth waypoint transitions.

Near SUA < 2 nm—Your position is within 2 nautical miles of an SUA, and your current course will not take you inside.

Need 2D Altitude—The unit needs altitude input in order to start and/or continue 2D navigation.

No DGPS Position—Not enough data is available to compute a DGPS position.

No RTCM Input—The beacon receiver is improperly connected or baud rates do not match.

Oscillator Needs Adjustment—The unit has detected excessive drift in its internal crystal oscillator which may result in longer acquisition time. Take the unit to an authorized service center.

Messages

Poor GPS Coverage—The unit cannot acquire the necessary number of satellites to compute a position. Try another location with a clearer view of the sky.

Power Down and Re-init—The unit is not able to calculate a position due to abnormal satellite conditions. Turn the unit off and verify the last position shown by other means. Try the unit again later, possibly in a different location.

Read Only Mem has Failed—The permanent memory has failed and the unit is not operable. Take the unit to an authorized service center.

Received an Invalid WPT—A waypoint was received during upload transfer that has an invalid identifier.

Route Waypoint Can't be Deleted—The waypoint you are trying to delete is part of a route. Delete the waypoint from the route before removing it from memory.

Receiver has Failed—A failure in receiver hardware has been detected. If this message persists, take the unit to an authorized dealer.

Route is Full—You have attempted to add more than 30 waypoints to a route.

Route is not Empty—You have attempted to copy into a route already in use.

Route Waypoint was Deleted—A route waypoint entered does not exist in the database and has been deleted from the route.

RTCM Input has Failed—DGPS data being received has been lost. You are no longer receiving the beacon signal.

Searching the Sky—The unit is in searching the sky for almanac data or the unit is in AutoLocate mode.

Start Altitude Change—The altitude change entered on the VNAV page is about to begin.

Steep Turn Ahead—This message appears approximately one minute prior to a turn that requires a bank angle in excess of 25 degrees in order to stay on course.

Stuck PTT—The unit is continuously transmitting due to a stuck microphone condition.

Stored Data was Lost—All waypoints, routes, time and almanac data has been lost due to battery failure or clearing the receiver's memory.

SUA Ahead < 10 min—Your projected course and current altitude will place you within a SUA within 10 minutes, based on your current track over ground.

SUA Near and Ahead—Your present position is within 2 nm of a SUA based upon your current course and altitude.

Timer Has Expired—The countdown timer has expired.

Transfer has been Completed—The receiver is finished uploading or downloading information to the connected device.

Vertical Nav Cancelled—The VNAV function has been cancelled due to a change in the active route.

Weather Alert Tone Detected—The unit has detected the NOAA severe weather tone.

WPT Memory is Full—You have used all 250 waypoints. Delete unwanted waypoints to make room for new entries.

Map Datums

The following list shows the map datums available for the GPSCOM 190. Menu page abbreviations are listed first, followed by the corresponding map datum name and area. The default map datum for the GPSCOM 190 is WGS 84.

Adindan	Adindan- Ethiopia, Mali, Senegal, Sudan	European 1950	European 1950- Austria, Belgium, Denmark, Finland, France, Germany, Gibraltar, Greece, Italy, Luxembourg, Netherlands, Norway, Portugal, Spain, Sweden, Switzerland
Afgooye	Afgooye- Somalia	European 1979	European 1979- Austria, Finland, Netherlands, Norway, Spain, Sweden, Switzerland
AIN EL ABD '70	AIN EL ANBD 1970- Bahrain Island, Saudi Arabia	Finland Hayfrd	Finland Hayford- Finland
Anna 1 Ast '65	Anna 1 Astro '65- Cocos Isl.	Gandajika Base	Gandajika Base- Republic of Maldives
ARC 1950	ARC 1950- Botswana, Lesotho, Malawi, Swaziland, Zaire, Zambia, Zimbabwe	Geod Datm '49	Geodetic Datum '49- New Zealand
ARC 1960	ARC 1960- Kenya, Tanzania	Guam 1963	Guam 1963- Guam Island
Ascnsn Isl'd '58	Ascension Island '58- Ascension Island	Gux 1 Astro	Gux 1 Astro- Guadalcanal Island
Astro B4 Sorol	Astro B4 Sorol Atoll- Tern Island	Hjorsey 1955	Hjorsey 1955- Iceland
Astro Bcn "E"	Astro Beacon "E"- Iwo Jima	Hong Kong '63	Hong Kong '63- Hong Kong
Astro Dos 71/4	Astro Dos 71/4- St. Helena	Hu-Tzu-Shan	Hu-Tzu-Shan- Taiwan
Astr Stn '52	Astronomic Stn '52- Marcus Island	Indian Bngldsh	Indian- Bangladesh, India, Nepal
Astrln Geod '66	Australian Geod '66- Australia, Tasmania Island	Indian Thailand	Indian- Thailand, Vietnam
Astrln Geod '84	Australian Geod '84- Australia, Tasmania Island	Indonesia '74	Indonesia 1974- Indonesia
Bellevue (IGN)	Efate and Erromango Islands	Ireland 1965	Ireland 1965- Ireland
Bermuda 1957	Bermuda 1957- Bermuda Islands	ISTS 073 Astro	ISTS 073 ASTRO '69- Diego Garcia
Bogata Observ	Bogata Observatry- Colombia	Johnston Island	Johnston Island Kandawala
Campo Inchspe	Campo Inchauspe- Argentina	Kerguelen Islnd	Kerguelen Island
Canton Ast '66	Canton Astro 1966- Phoenix Islands	Kertau 1948	Kertau 1948- West Malaysia, Singapore
Cape	Cape- South Africa	L. C. 5 Astro	Cayman Brac Island
Cape Canavrl	Cape Canaveral- Florida, Bahama Islands	Liberia 1964	Liberia 1964- Liberia
Carthage	Carthage- Tunisia	Luzon Mindanao	Luzon- Mindanao Island
CH-1903	CH 1903- Switzerland	Luzon Philippine	Luzon- Philippines (excluding Mindanao Island)
Chatham 1971	Chatham 1971- Chatham Island (New Zealand)	Mahe 1971	Mahe 1971- Mahe Island
Chua Astro	Chua Astro- Paraguay	Marco Astro	Marco Astro- Salvage Island
Corrego Alegre	Corrego Alegre- Brazil	Massawa	Massawa- Eritrea (Ethiopia)
Djakarta	Djakarta (Batavia)- Sumatra Island (Indonesia)	Merchich	Merchich- Morocco
Dos 1968	Dos 1968- Gizo Island (New Georgia Islands)	Midway Ast '61	Midway Astro '61- Midway
Easter Isl'd 67	Easter Island 1967	Minna	Minna- Nigeria

Map Datums

NAD27 Alaska	North American 1927- Alaska	Prov S Am '56	Prov So Amrcn '56- Bolivia, Chile, Colombia, Ecuador, Guyana, Peru, Venezuela
NAD27 Bahamas	North American 1927- Bahamas (excluding San Salvador Island)	Prov S Chln '63	Prov So Chilean '63- S. Chile
NAD27 Canada	North American 1927- Canada and Newfoundland	Puerto Rico	Puerto Rico & Virgin Islands
NAD27 Canal Zone	North Am. 1927- Canal Zone	Qatar National	Qatar National- Qatar
NAD27 Caribbn	North American 1927- Caribbean (Barbados, Caicos Islands, Cuba, Dom. Rep., Grand Cayman, Jamaica, Leeward and Turks Islands)	Qornoq	Qornoq- South Greenland
NAD27 Central	North American 1927- Central America (Belize, Costa Rica, El Salvador, Guatemala, Honduras, Nicaragua)	Reunion	Reunion- Mascarene Island
NAD27 CONUS	North Am. 1927- Mean Value	Rome 1940	Rome 1940- Sardinia Island
NAD27 Cuba	North American 1927- Cuba	RT 90	Sweden
NAD27 Grnland	North American 1927- Greenland (Hayes Peninsula)	Santo (Dos)	Santo (Dos)- Espirito Santo Island
NAD27 Mexico	N. American 1927- Mexico	Sao Braz	Sao Braz- Sao Miguel, Santa Maria Islands (Azores)
NAD27 San Sal	North American 1927- San Salvador Island	Sapper Hill '43	Sapper Hill 1943- East Falkland Island
NAD83	North American 1983- Alaska, Canada, Central America, CONUS, Mexico	Schwarzeck	Schwarzeck- Namibia
Nhrwn Masirah	Nahrwn- Masirah Island (Oman)	Sth Amrcn '69	South American '69- Argentina, Bolivia, Brazil, Chile, Colombia, Ecuador, Guyana, Paraguay, Peru, Venezuela, Trinidad and Tobago
Nhrwn Saudi A	Nahrwn- Saudi Arabia	South Asia	South Asia- Singapore
Nhrwn United A	Nahrwn- United Arab Emirates	SE Base	Southeast Base- Porto Santo and Madeira Islands
Naparima BWI	Naparima BWI- Trinidad and Tobago	SW Base	Southwest Base- Faial, Graciosa, Pico, Sao Jorge and Terceira Islands (Azores)
Obsrvtorio '66	Observatorio 1966- Corvo and Flores Islands (Azores)	Timbalai 1948	Timbalai 1948- Brunei and E. Malaysia (Sarawak and Sabah)
Old Egyptian	Old Egyptian- Egypt	Tokyo	Tokyo- Japan, Korea, Okinawa
Old Hawaiian	Old Hawaiian- Mean Value	Tristan Ast '68	Tristan Astro 1968- Tristan da Cunha
Oman	Oman- Oman	Viti Levu 1916	Viti Levu 1916- Viti Levu/ Fiji Islands
Ord Srvy GB	Old Survey Grt Britn- England, Isle of Man, Scotland, Shetland Isl., Wales	Wake-Eniwetok	Wake-Eniwetok- Marshall Isl.
Pico De Las Nv	Canary Islands	WGS 72	World Geodetic System 1972
Ptcairn Ast '67	Pitcairn Astro '67- Pitcairn Isl.	WGS 84	World Geodetic System 1984
		Zanderij	Zanderij- Surinam

Time Offset Chart

Time Offset Chart

Reference the table below to find the UTC-to-local time offset for your longitudinal zone. If you are in a day-light savings time zone, add one hour to the offset. For example, if you are at longitude W081.0°00.00' and UTC time is 16:00, local time is 11:00 standard time. The time zone boundaries given below may be different depending on your area. Consult your charts for more accurate information concerning time zones.

Longitudinal Zone	Offset	Longitudinal Zone	Offset
W180.0° to W172.5°	-12	E007.5° to E022.5°	1
W172.5° to W157.5°	-11	E022.5° to E037.5°	2
W157.5° to W142.5°	-10	E037.5° to E052.5°	3
W142.5° to W127.5°	-9	E052.5° to E067.5°	4
W127.5° to W112.5°	-8	E067.5° to E082.5°	5
W112.5° to W097.5°	-7	E082.5° to E097.5°	6
W097.5° to W082.5°	-6	E097.5° to E112.5°	7
W082.5° to W067.5°	-5	E112.5° to E127.5°	8
W067.5° to W052.5°	-4	E127.5° to E142.5°	9
W052.5° to W037.5°	-3	E142.5° to E157.5°	10
W037.5° to W022.5°	-2	E157.5° to E172.5°	11
W022.5° to W007.5°	-1	E172.5° to E180.0°	12
W007.5° to E007.5°	0		

A

Accessories	87
Acquiring Satellites	8
Activating a GOTO	12
Activating a Route	49
Active Frequency	11
Active Route Page	50
Adapter Cable	85
Alphanumeric Data Entry	11
Aircraft Radio Station License	ii
Airport Communication Page	26
Airport Information	25
Airport Location Page	26
Alarm and CDI Functions	72
Altitude Buffer	74
Arrival Alarms	74
Audio/Display Options	65
Auto Zoom	20, 60
AutoLocate	6, 7

B

Backlight Timer	65
Battery Handling and Storage	89
Battery Pack Removal	88
Battery Voltage Display	52
Belt Clip	87

C

Cancel GOTO Navigation	44
Canceling GOTO Navigation	21
Carrying Case	87
Cautions	iv
CDI Alarm & Scale	75
Cigarette Lighter Adapter	84
Condition Alerts	92
Clearing a Route	49
Com Frequency Page	36
Com Function Page	34
Com Memory Page	36
Com Menu Page	38
Com Page Sequence	34
Com Setup Submenu	38
Copying and Clearing Routes	48
Creating a Route	48

D

Database Issue Date	6
Database Page	9
Date/Time and Timer Options	66
Density Altitude	75
DGPS Interface Setup	70
DTK	50

E

E6-B Menu	75
Emergency Channel Selection	20
Emergency Freq Selection	42
Entering Identifiers	24
Entering an Altitude	13
ETA	50
EZinit Prompt	7, 53

F

Flex Com Antenna	87
Frequency Entry	10
Frequency Information Page	37

G

GBR-21 Beacon Receiver	70
GOTO Function	43, 44

H

Heading Display	64
Headset/Mic/DC Adapter	84

I

Initial Position Entry	63
Initializing The Receiver	6
Interface Setup	69
Internal Database	23
Intersection Information	28
Intersection Page	28
Internal Patch Antenna	6

*Index***J**

Jeppesen database 9, 71

K

Keys and Controls 4

L

Lithium Battery 89

M

Magnetic Heading 64

Main Menu Page 62

Map Airspace Options 59

Map Configuration 58

Map Datums 94

Map Page 55

Map Page Functions 56

Map Orientation 60

Map Waypoints 58

Memory Changes 41

Memory Comments 41

Memory Setup Submenu 41

Memory Write and Recall 36

Messages 92

Messages Page 81

Moving Map Page 14

N

NDB Information 28

NDB Page 28

National Weather Service 38

Navigation Page 13

Navigation Units 64

Nearest ARTCC Page 17, 32

Nearest Airports 71

Nearest FSS Page 17, 32

Nearest Pages 32

Nearest Waypoints Page 17

Ni-Cad Battery Pack 6

O

On-Route GOTOs 51

Operational Mode Page 63

P

Packing List iii

Page Sequence 10

Pan Function 56

Plot Points 60

Position /Datum 65

Position Page 14, 54

Power On 9

R

Range Rings 60

Receiver Status 53

Reference Waypoint Comments 30

Remote Antenna Installation 8

Remote GPS Antenna 86

Repair 90

Reviewing & Editing Routes 51

Route Definition Page 47

Route Planning 77

Routes 59

Routes Submenu 81

Runway Information Page 16

Runway Page 27

S

Satellite Status Page 52

Scan Setup Submenu 39

Scanning 34

Scanning Direction 40

Screen Contrast 66

Sectorized Boundaries 16

Seek Setup Menu 40

Seek Setup Submenu 40

Seeking 35

Selecting a Frequency 16

Setup Menu 62

Signal Strength Bars 52

Simulator Mode 11

Software Version i0

Specifications 90

Speed Entry 13

Sky View 52

Index

Squelch	.6
Standby Frequency	.11
Status Page	.9
Stuck Microphone	.39
SUAs	.16, 17
SUA Alarms	.72
SUA Messages	.16
Sunrise/Sunset Calculator	.77

T

Target Crosshair	.56
Temporary Alerts	.92
Time Delay	.40
Time Offset	.66
Time Offset Chart	.96
Timer Function	.66
Tips on TracBack	.46
Tone Mode	.66
TracBack Function	.68
TracBack Navigation	.45, 46
TracBack Route	.46
Track Log Options	.67
Track Log Page	.67
Track Log Setup	.68
Transceiver Description	.33
Trickle Charger/AC Adapter	.89
Trip and Fuel Planning	.76
Trip Odometer	.14
True Air Speed	.75

U

Unit Description	.2
User Waypoint Information	.29
User Waypoint List	.80

V

Vertical Navigation	.78
VNAV Calculation	.78
VOR Duplex Operation	.39
VOR Information	.28

W

Warranty	.100
Waypoint Categories	.23
Welcome Page	.6
Wrist Strap	.87
Winds Aloft Function	.76

Y

Yoke Mount	.82
------------	-----

Z

Zooming and Panning	.56
---------------------	-----

GARMIN LIMITED WARRANTY

GARMIN warrants this product to be free from defects in materials and workmanship for one year from the date of purchase. GARMIN International, Inc. will at its sole option, repair or replace any components which fail in normal use. Such repairs or replacement will be made at no charge to the customer for parts or labor. The customer is, however, responsible for any transportation costs. This warranty does not cover failures due to abuse, misuse, accident or unauthorized alteration or repairs. GARMIN International, Inc. assumes no responsibility for special, incidental, punitive or consequential damages, or loss of use.

The warranties and remedies contained herein are exclusive and in lieu of all other warranties expressed or implied, including any liability arising under warranty of merchantability or fitness for a particular purpose, statutory or otherwise. This warranty gives you specific legal rights, which may vary from state to state.

To obtain warranty service, call the GARMIN Customer Service department for a returned merchandise tracking number. The unit should be securely packaged with the tracking number clearly marked on the outside of the package, and sent freight prepaid and insured to a GARMIN warranty service station. A copy of the original sales receipt is required as the proof of purchase for warranty and flat rate repairs.

Once your standard warranty expires, GARMIN's flat rate service policy provides a low-cost, fast-turnaround factory repair for three additional years. The flat rate is set at the time of purchase, and costs you nothing until you need it. If your GPS should ever need service or repair, return it to a GARMIN service center.

The flat rate service policy applies to the original owner, and is void if the product exhibits any evidence of physical abuse, neglect or intentional damage determined at the sole discretion of GARMIN.

A copy of the original sales receipt is required to verify the service rate in effect at the time of purchase. If a receipt is not available or not included with the unit, it will be repaired at the current three-year flat rate.

Software and database updates are not included in the warranty or flat rate program. GARMIN may, however, change the operating software and/or database at its discretion at no additional cost. Unit repair or replacement will be made at the sole discretion of GARMIN.



Guidance by
GARMIN



© 1996 GARMIN CORPORATION

1200 E. 151st Street, Olathe, KS USA 66062

GARMIN (Europe) LTD

Unit 5, The Quadrangle, Abbey Park Industrial Estate, Romsey, U.K. SO51 9AQ

Part Number 190-00110-00 Rev. B